

Materiales	
M1	Acero inoxidable S316L
M2	Fundición de aluminio anodizado color
M3	Fundición de aluminio anodizado natural
M4	Neopreno

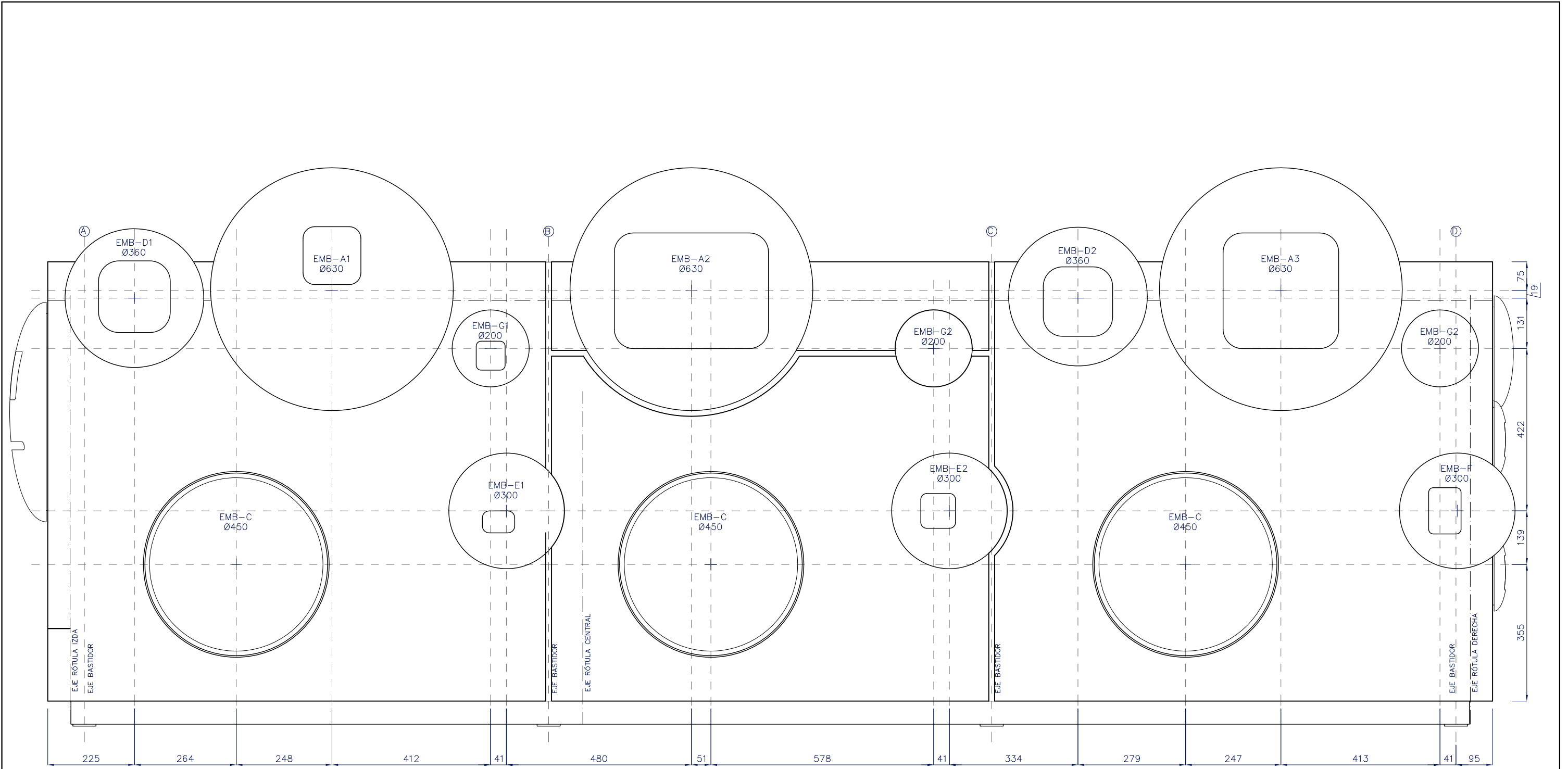

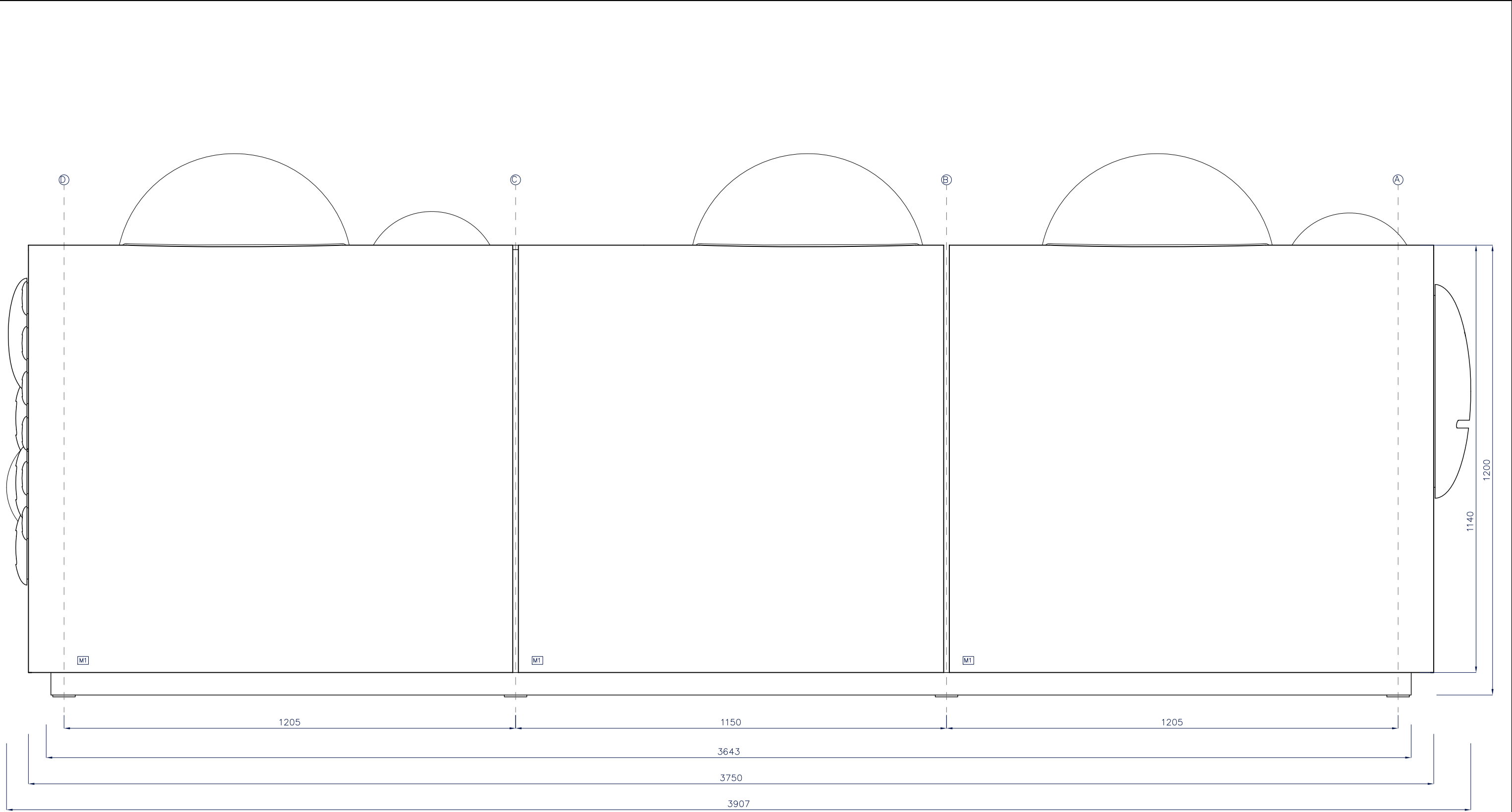

Materiales
M1 Acero inoxidable S316L
M2 Fundición de aluminio anodizado color
M3 Fundición de aluminio anodizado natural
M4 Neopreno

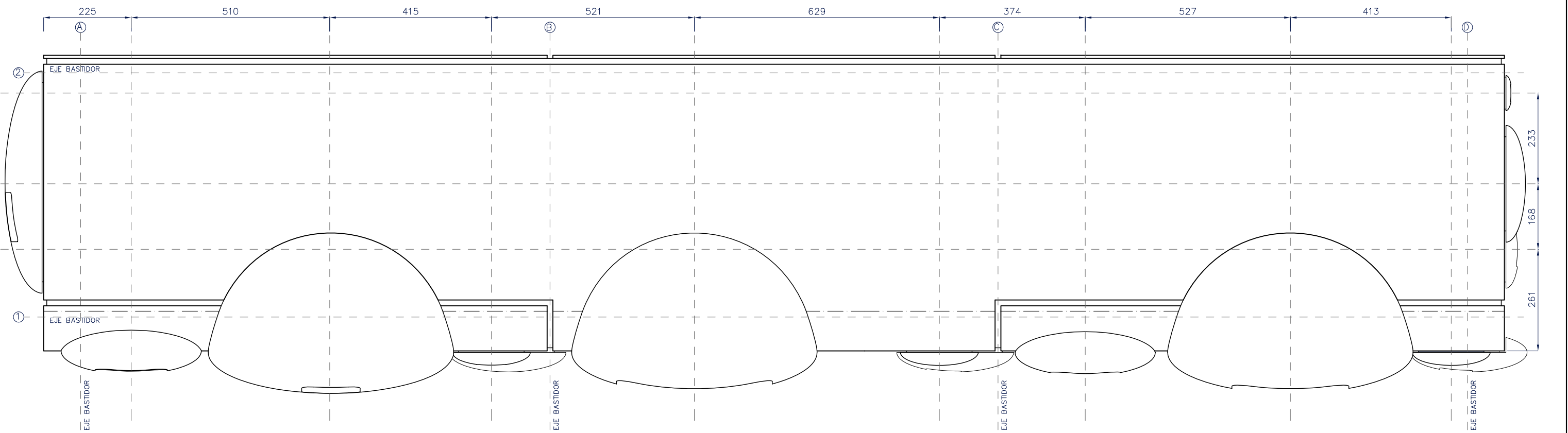
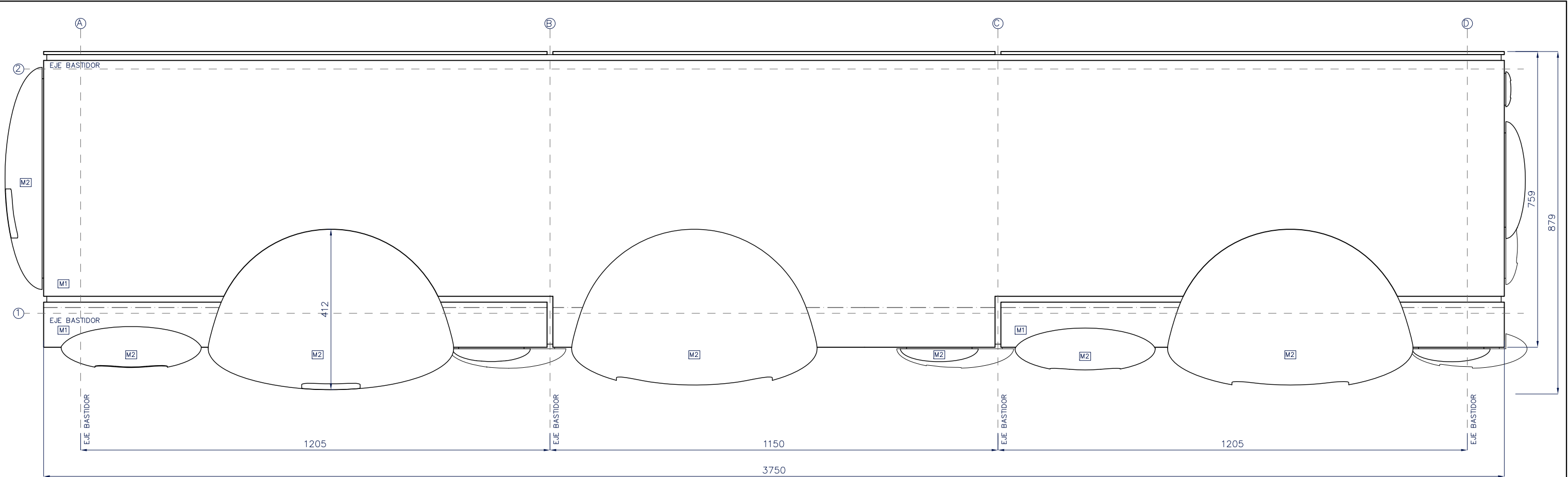

Materiales	
M1	Acero inoxidable S316L
M2	Fundición de aluminio anodizado color
M3	Fundición de aluminio anodizado natural
M4	Neopreno

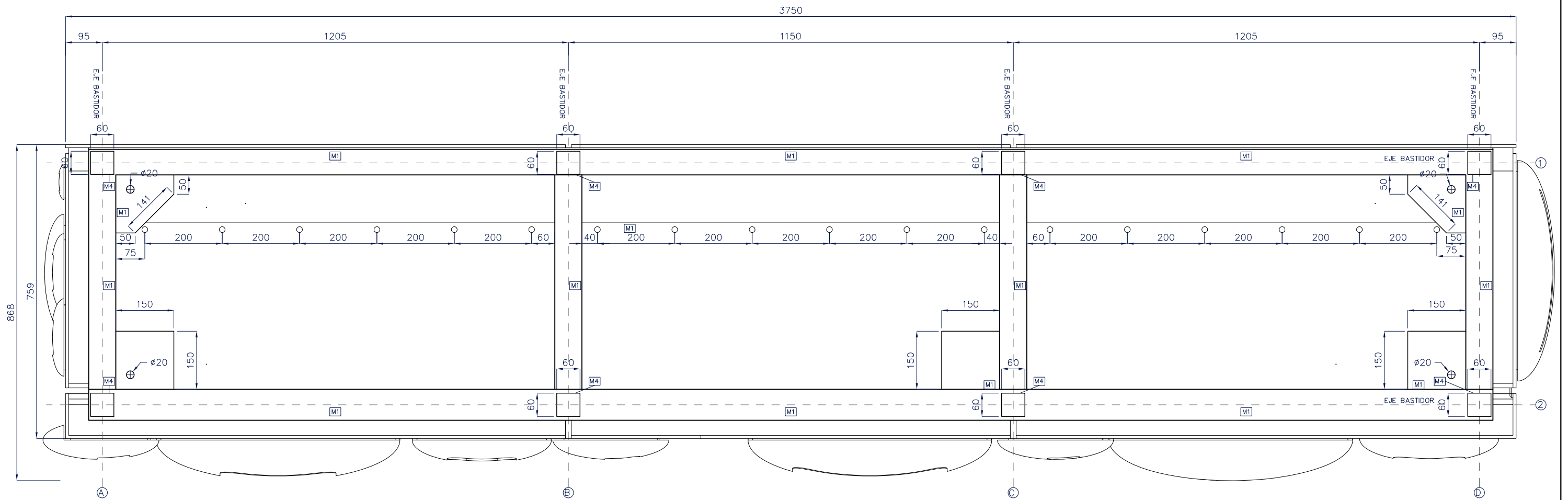

Materiales	
M1	Acero inoxidable S316L
M2	Fundición de aluminio anodizado color
M3	Fundición de aluminio anodizado natural
M4	Neopreno

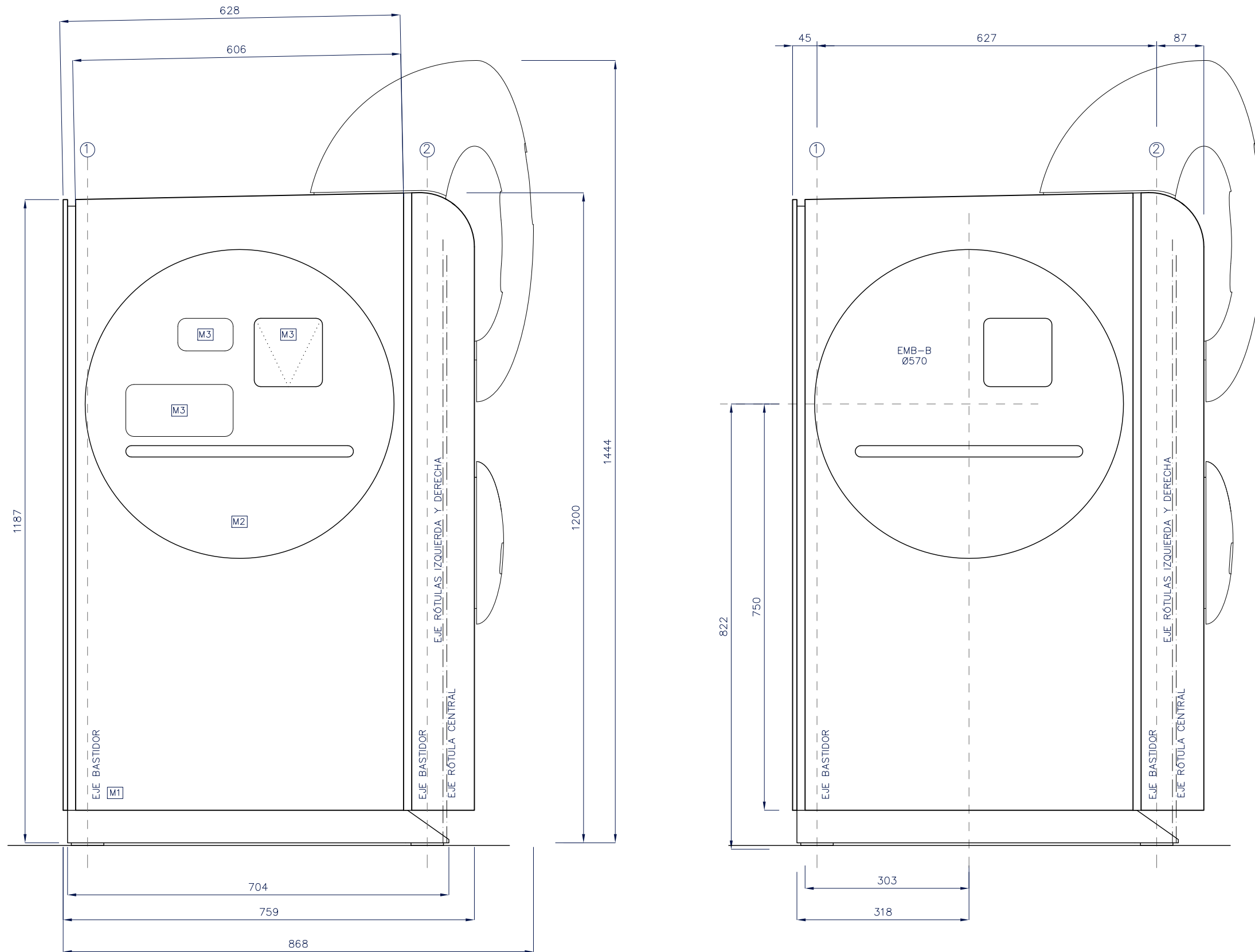

Materiales	
M1	Acero inoxidable S316L
M2	Fundición de aluminio anodizado color
M3	Fundición de aluminio anodizado natural
M4	Neopreno

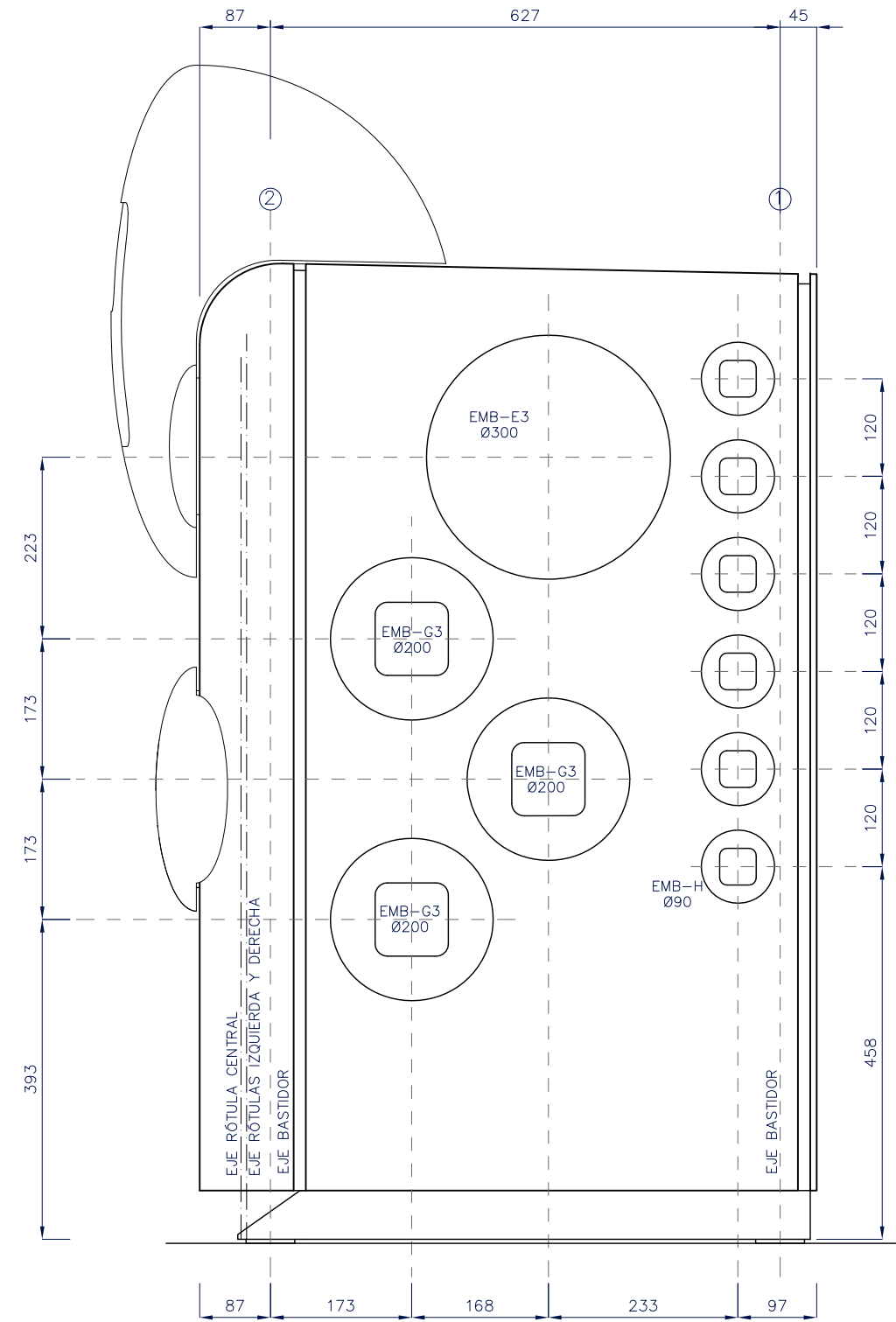
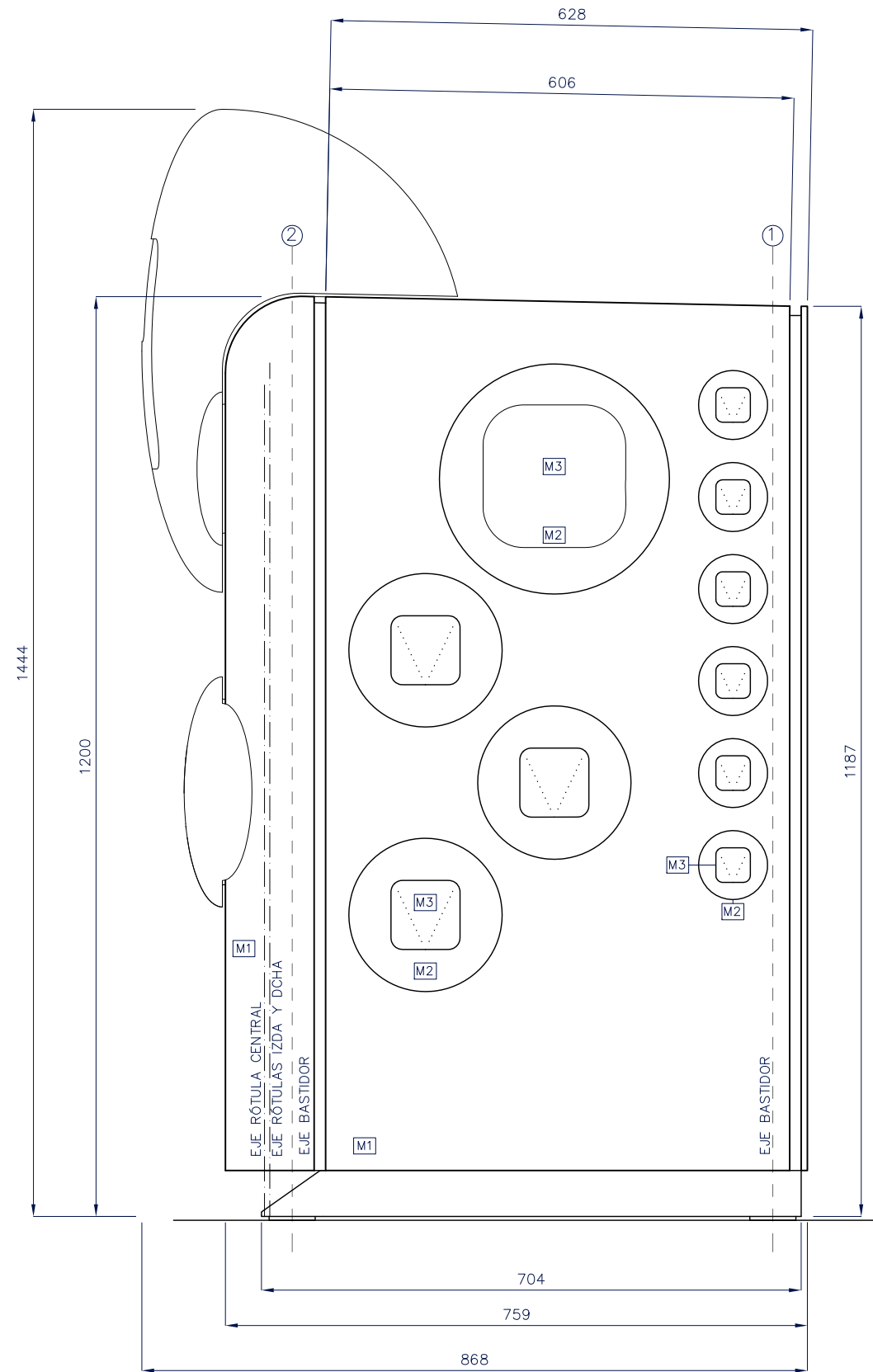

Materiales	
M1	Acero inoxidable S316L
M2	Fundición de aluminio anodizado color
M3	Fundición de aluminio anodizado natural
M4	Neopreno

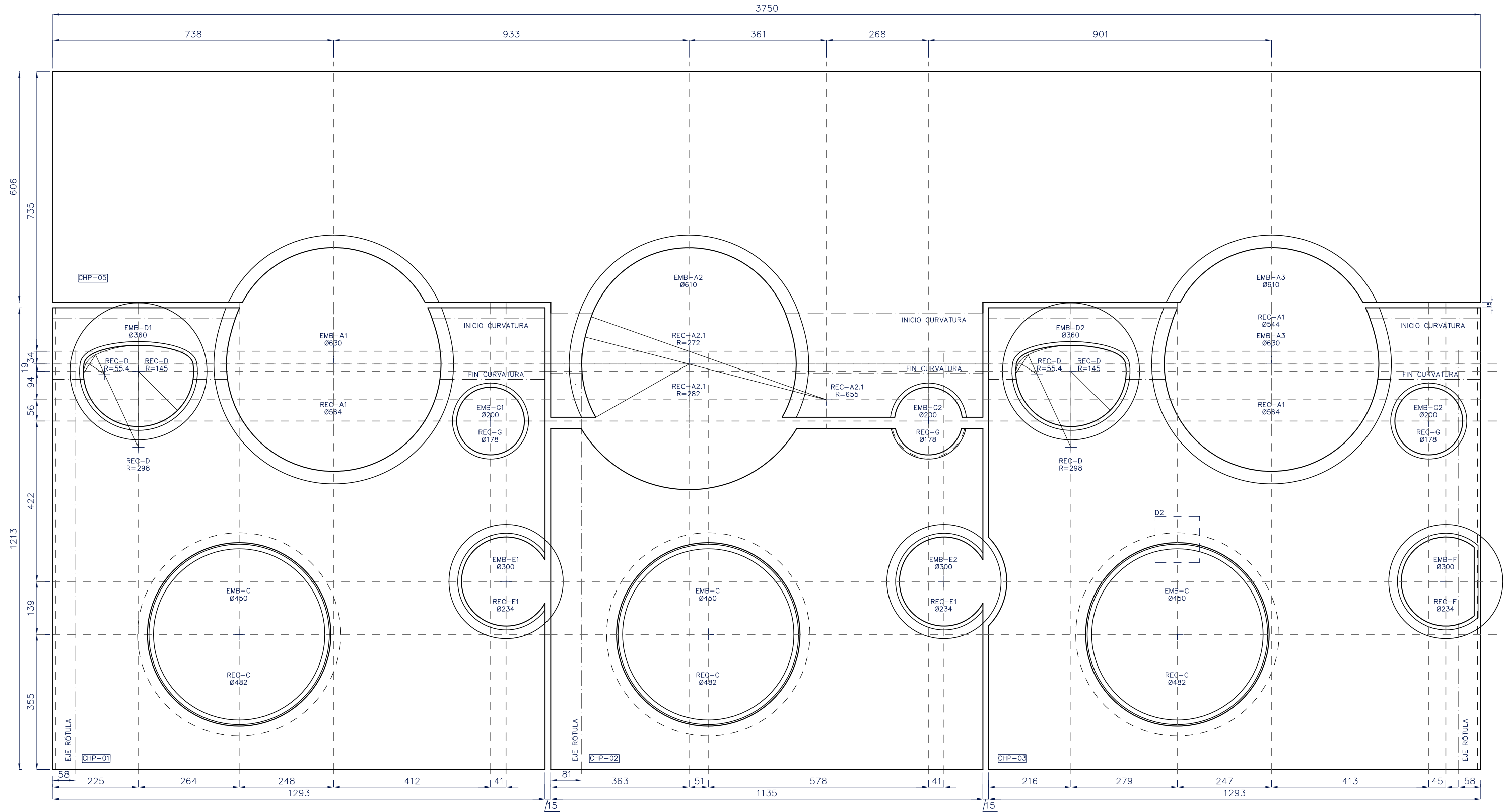

EMB - Embocadura  
REC - Recorte



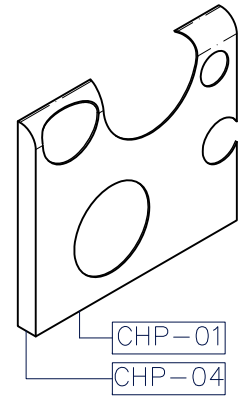

EMB - Embocadura  
REC - Recorte

SECCIÓN A-A'

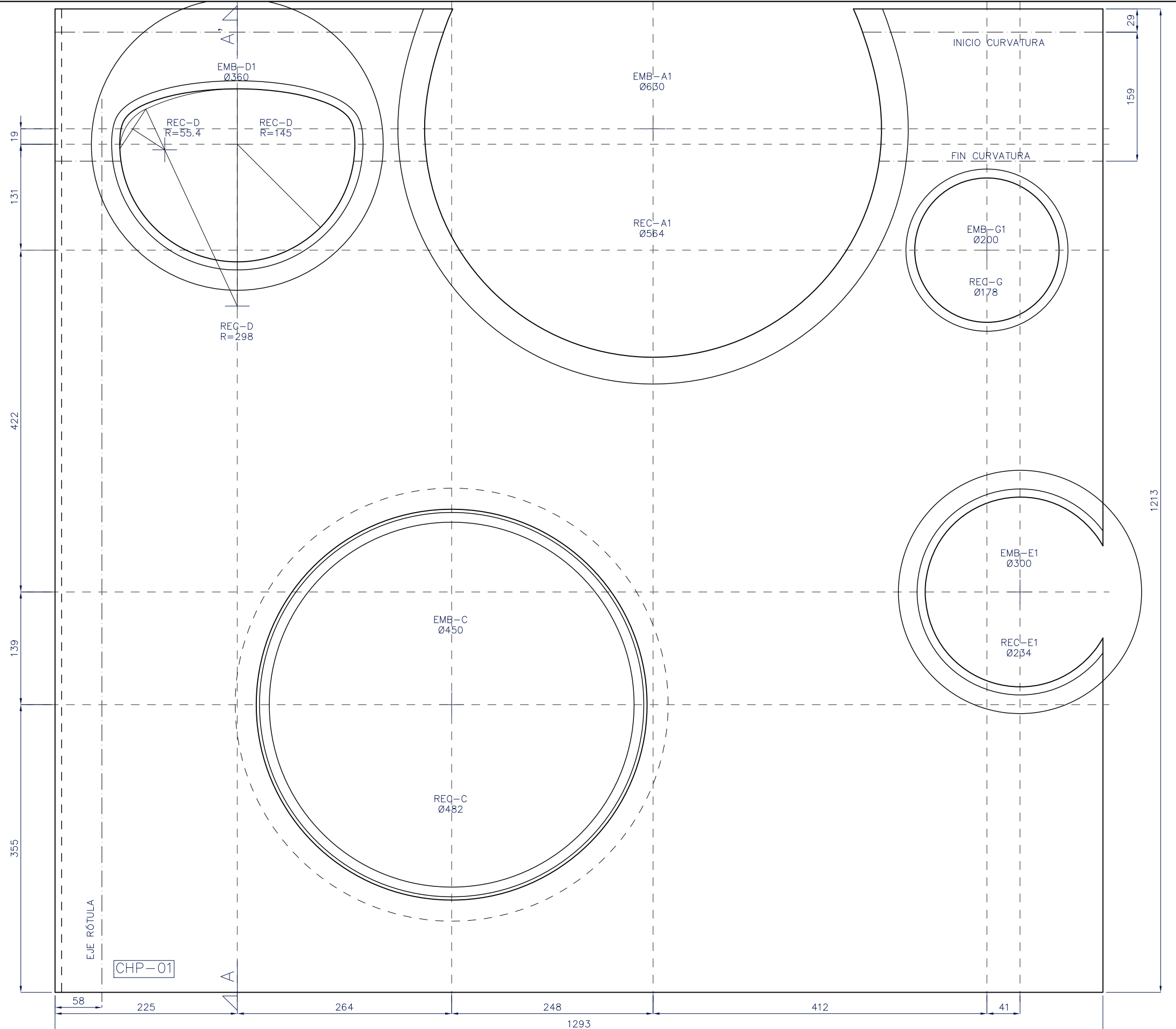
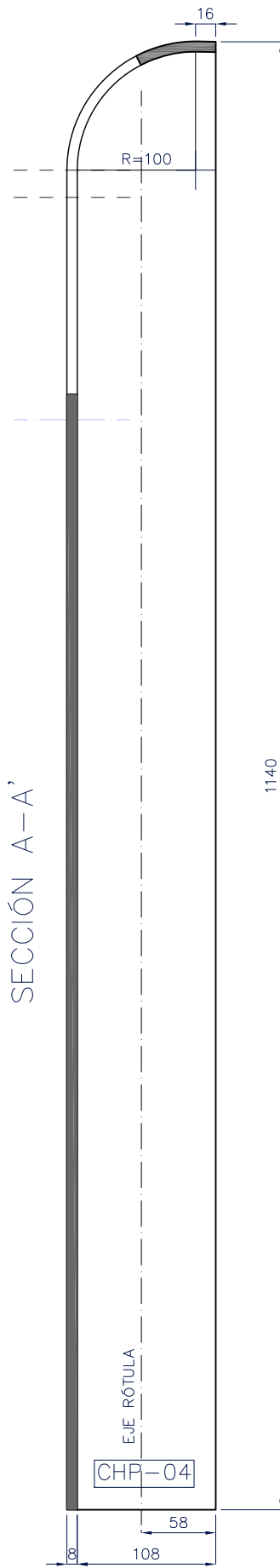

EMB - Embocadura  
REC - Recorte

SECCIÓN B-B'

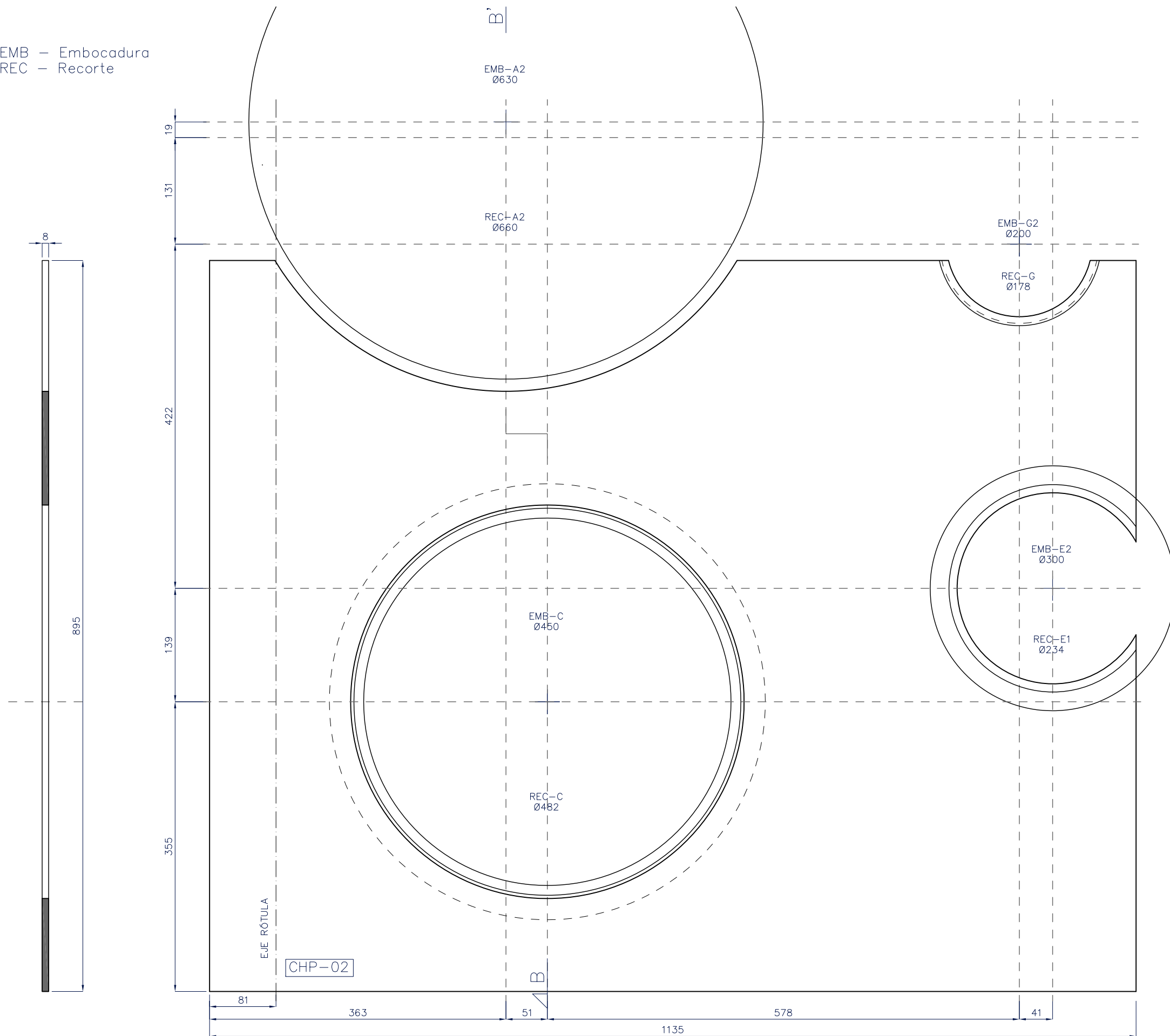

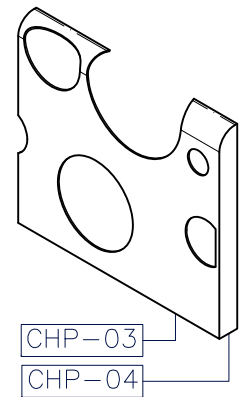

EMB - Embocadura  
REC - Recorte

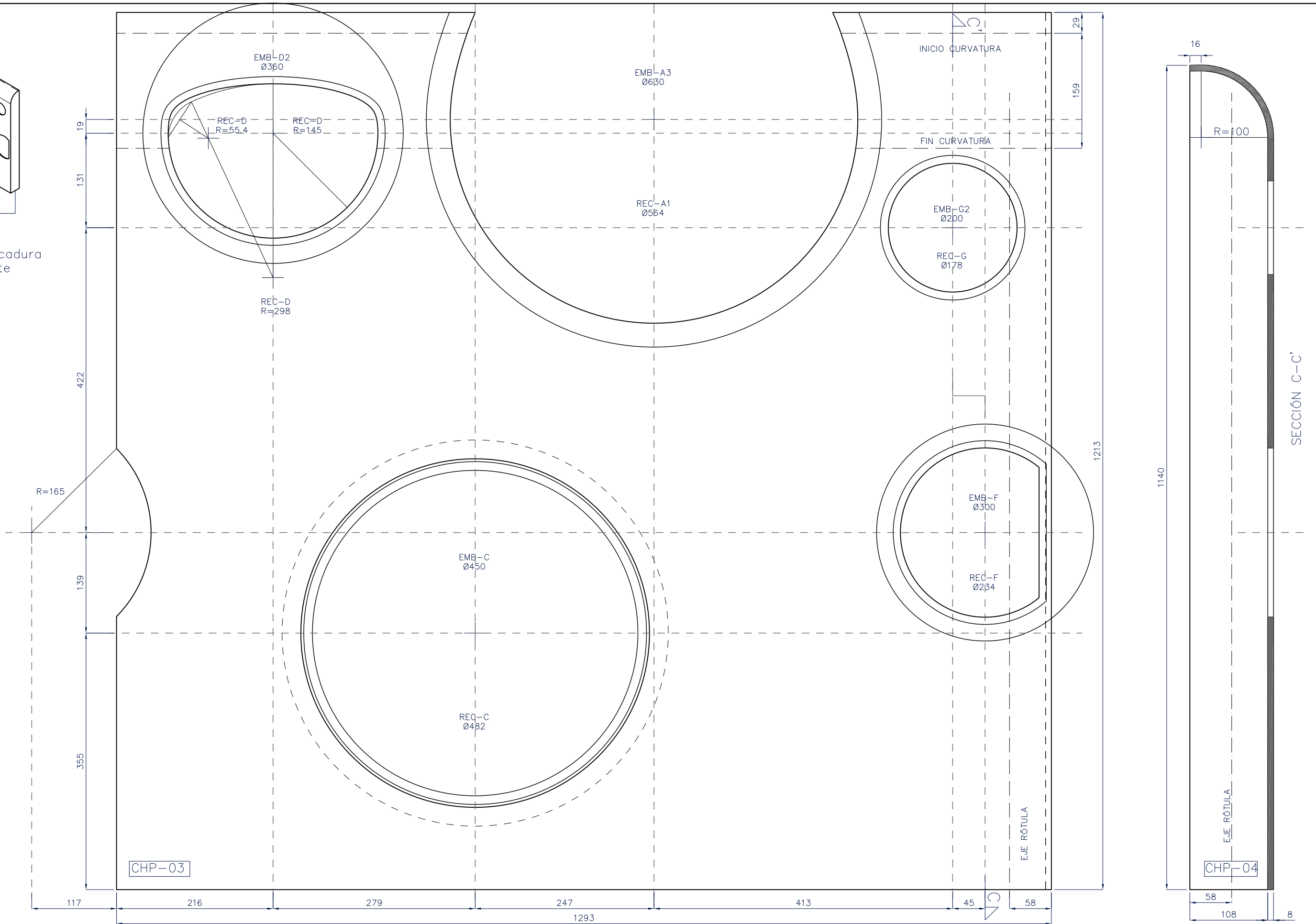

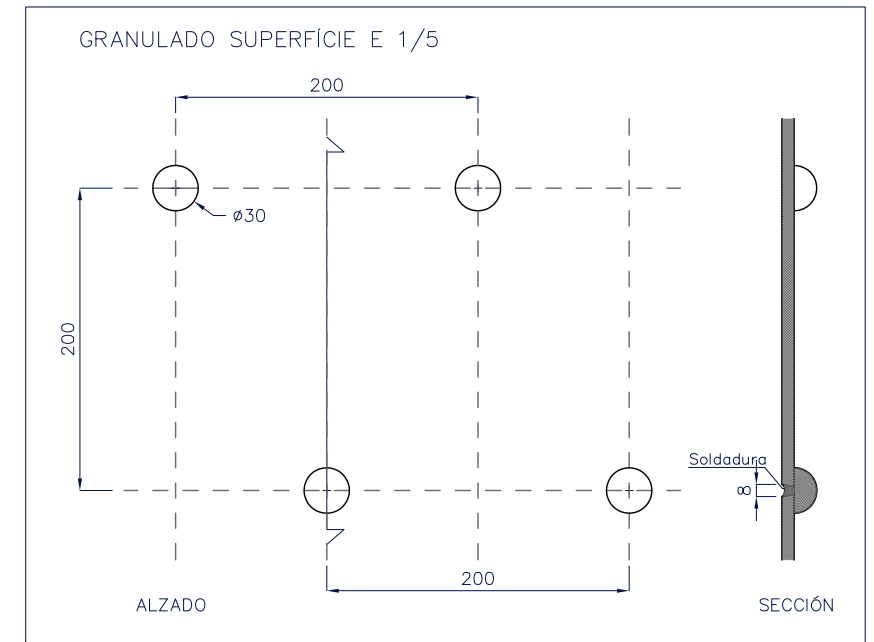
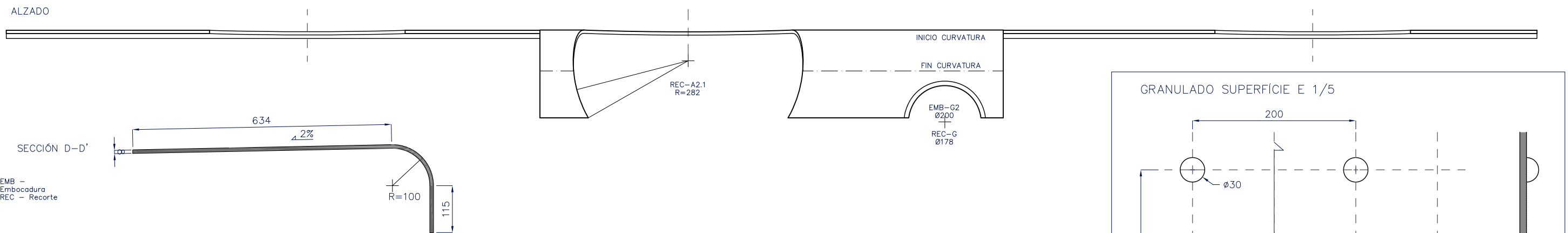
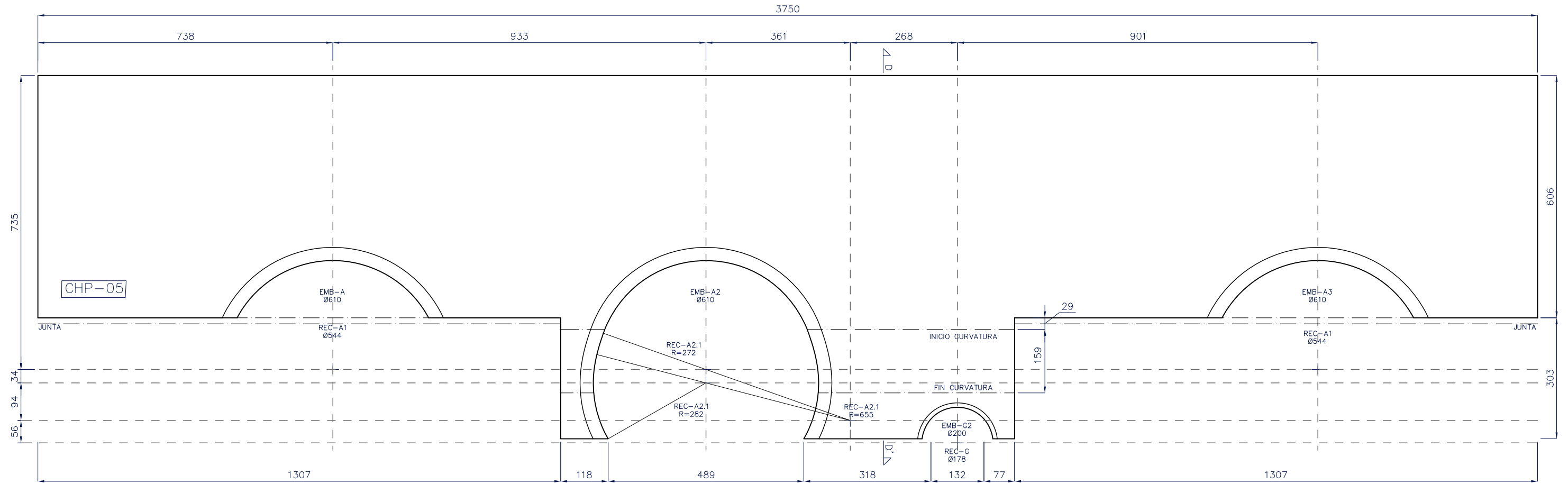

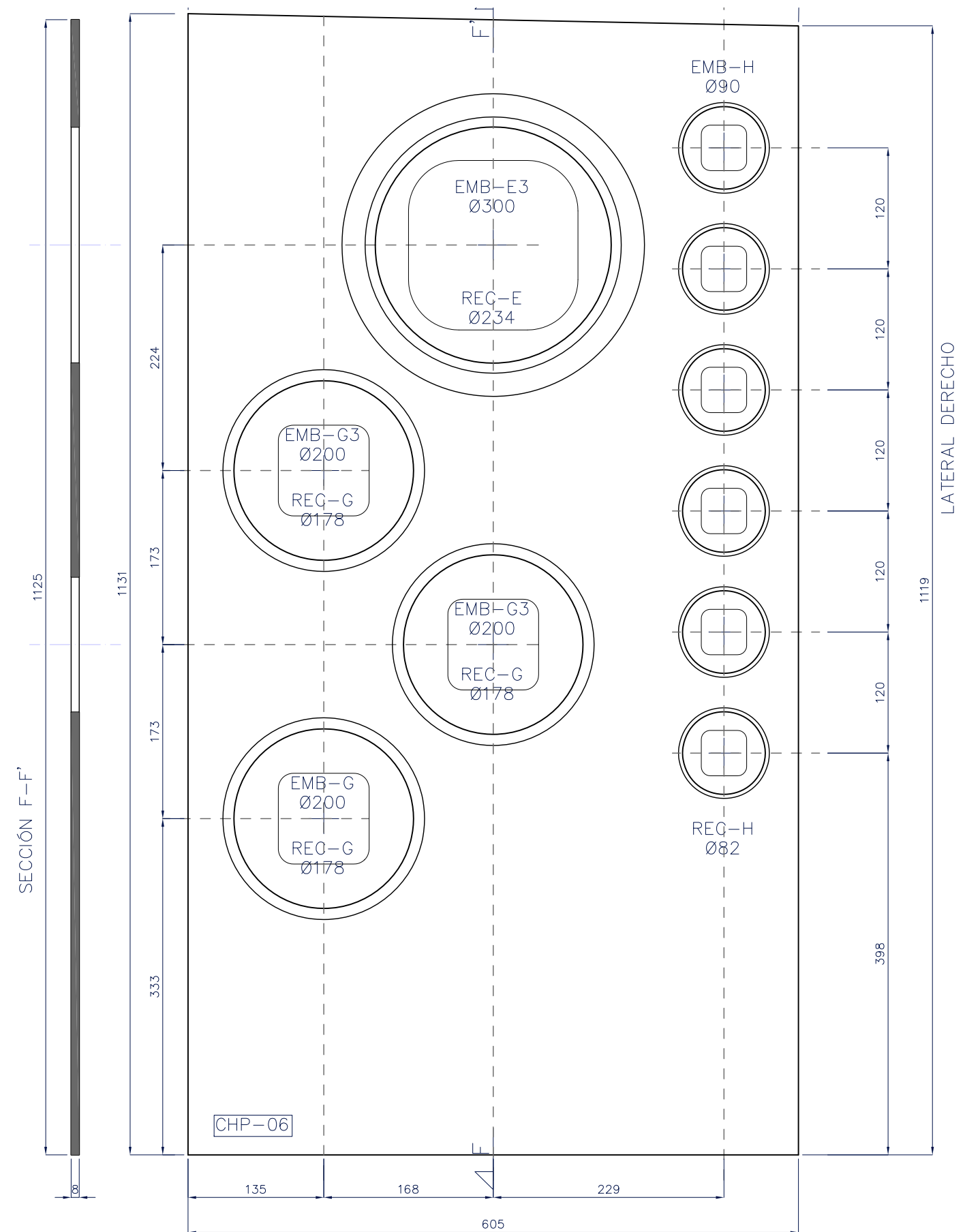
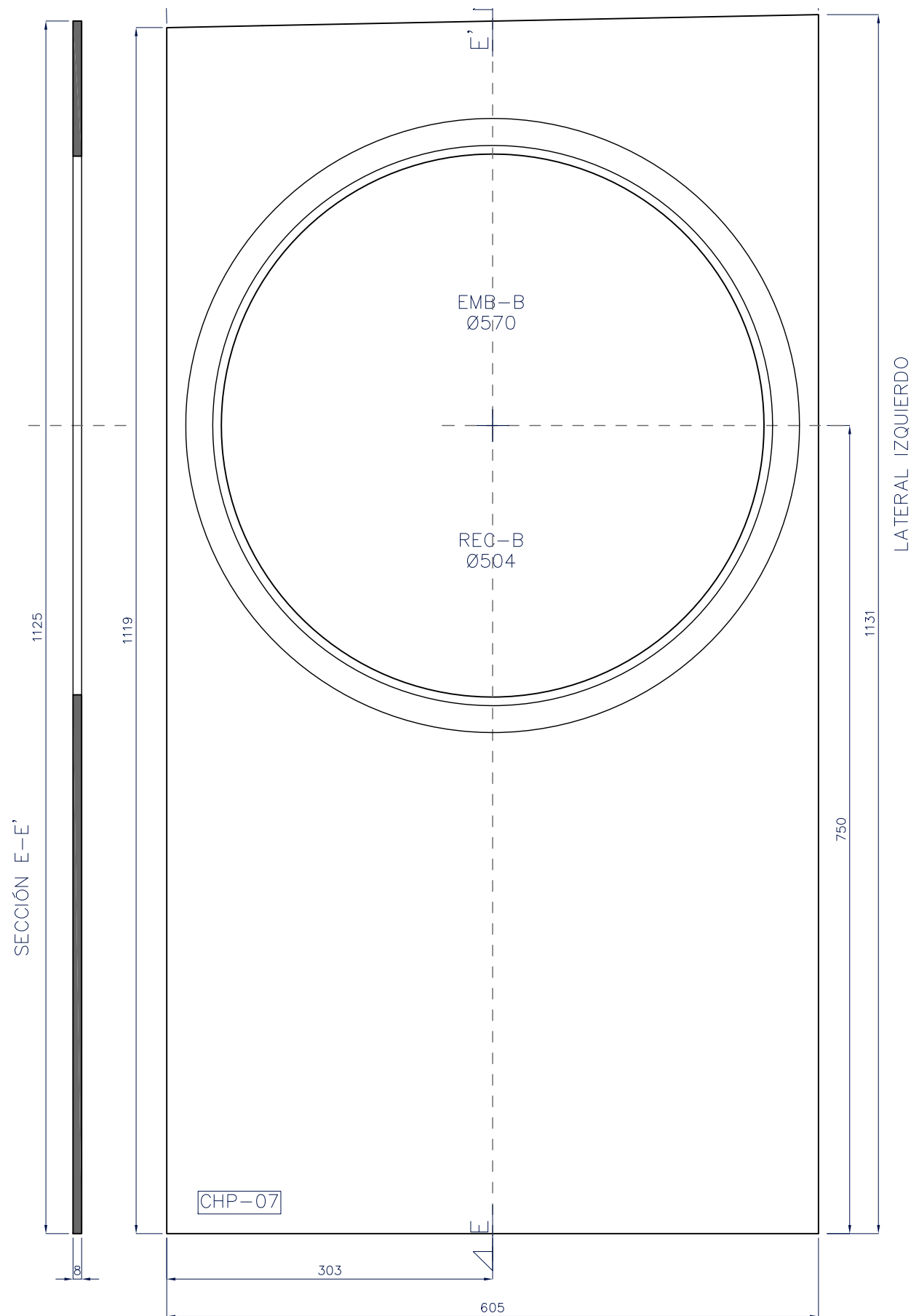

ALZADO POSTERIOR

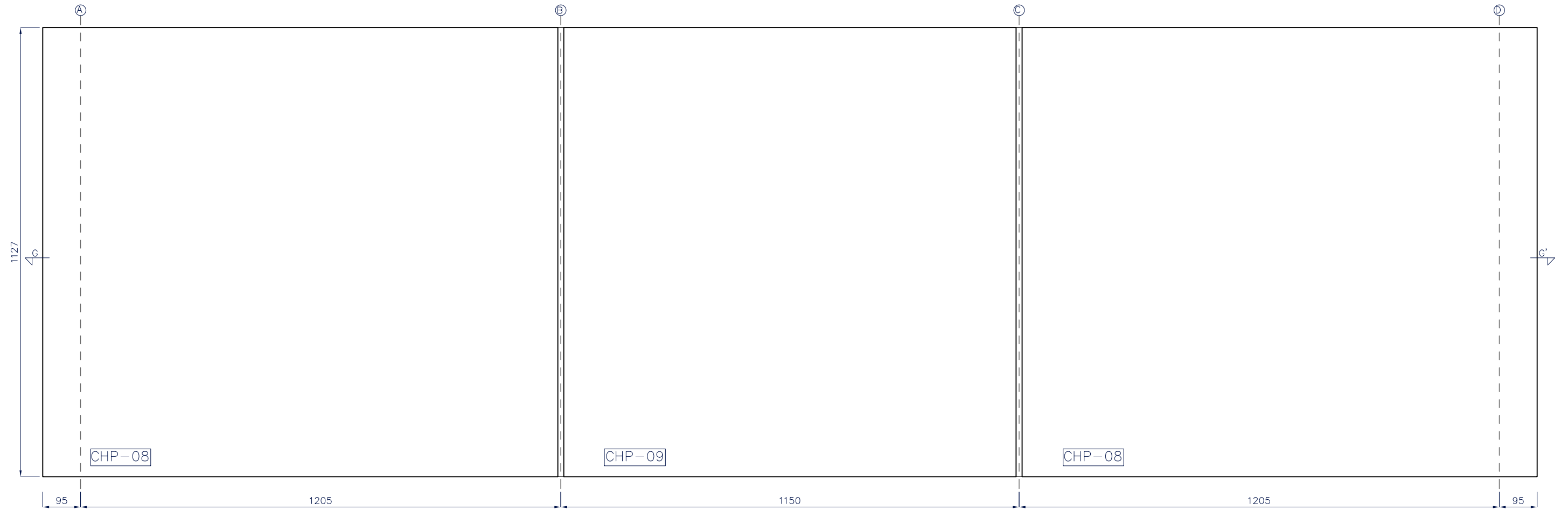

SECCIÓN G-G'





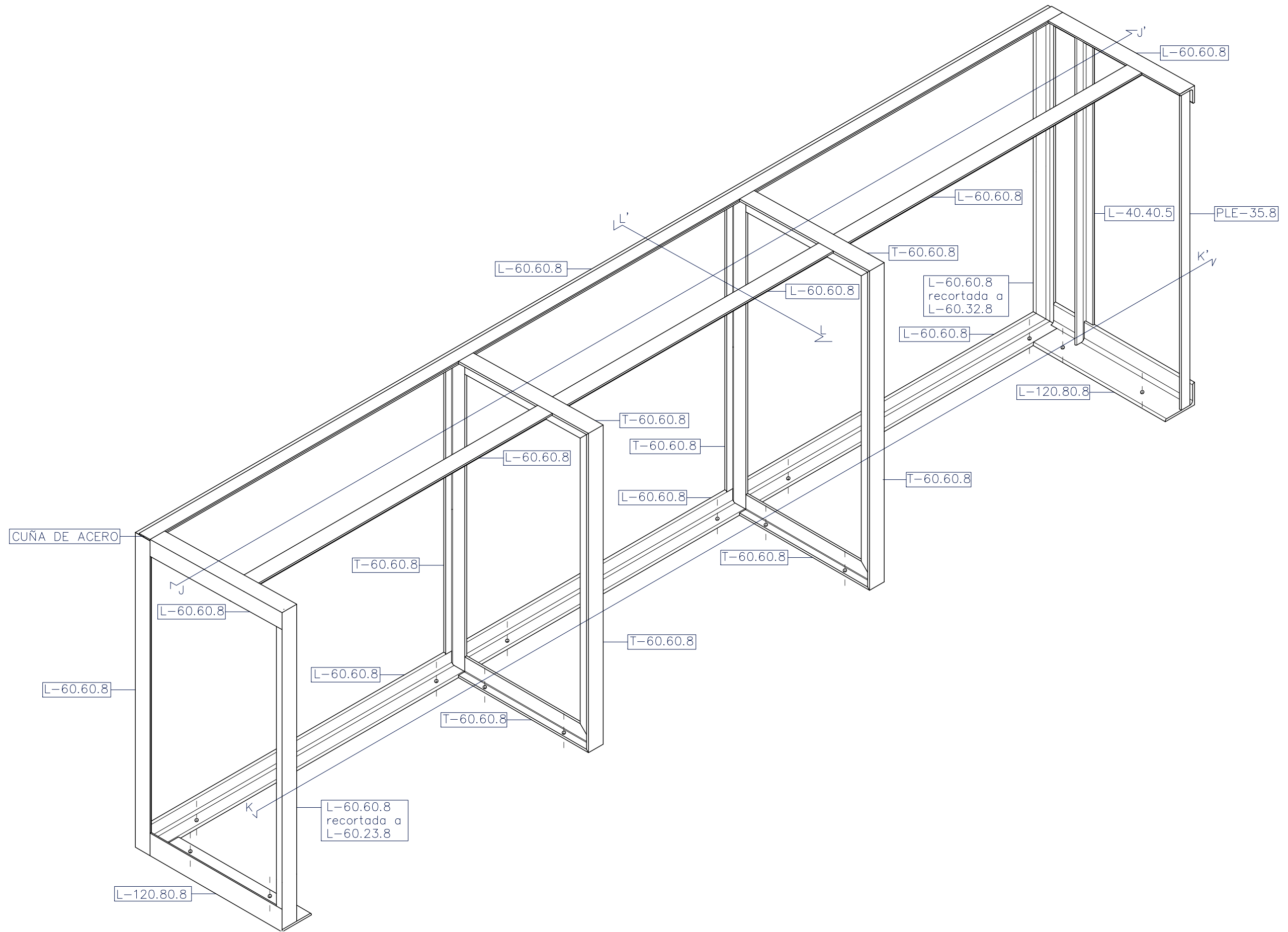



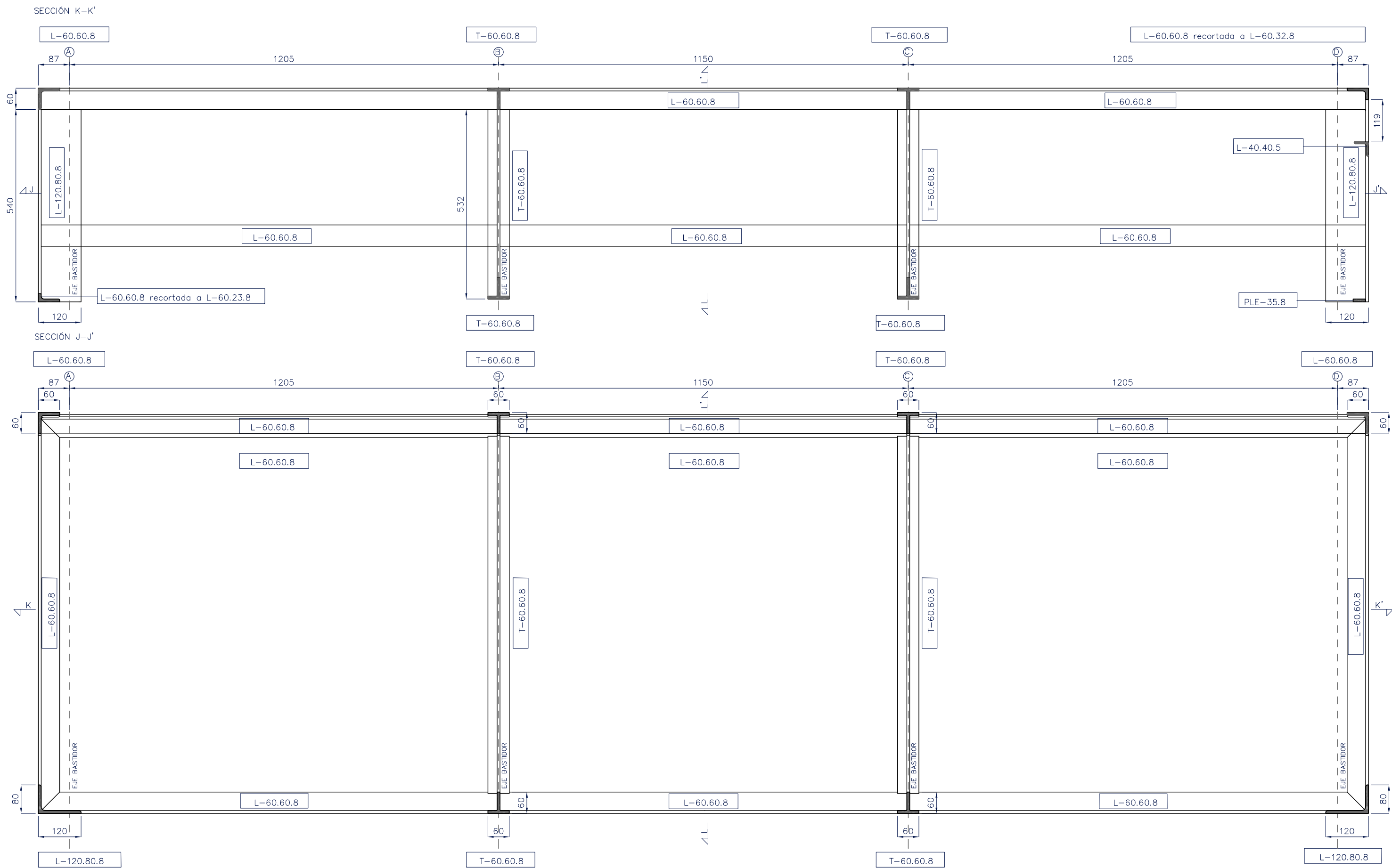

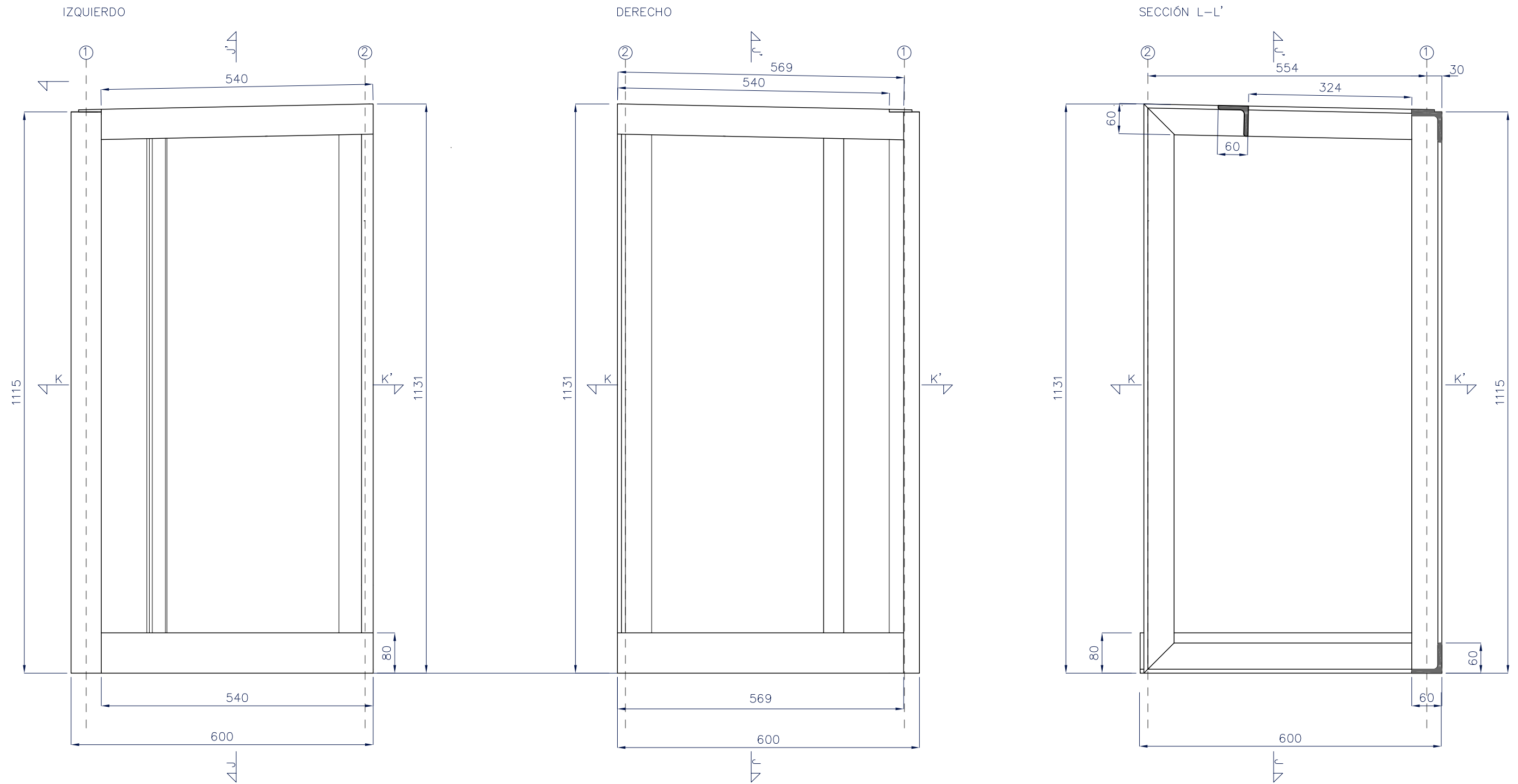

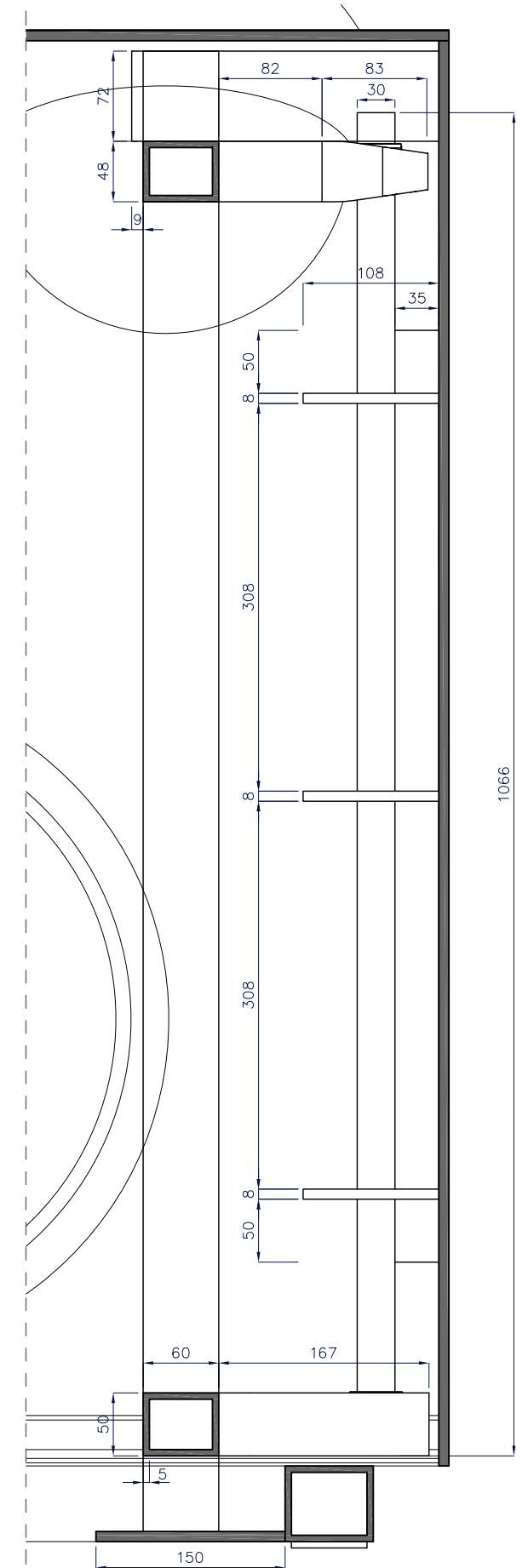
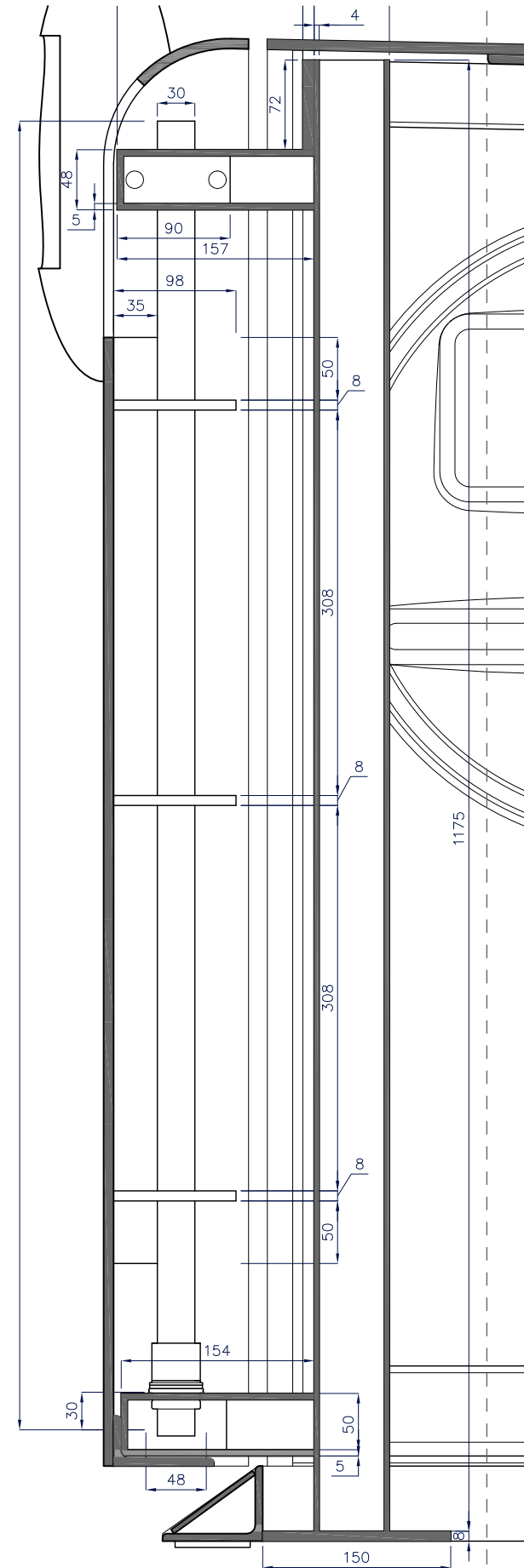
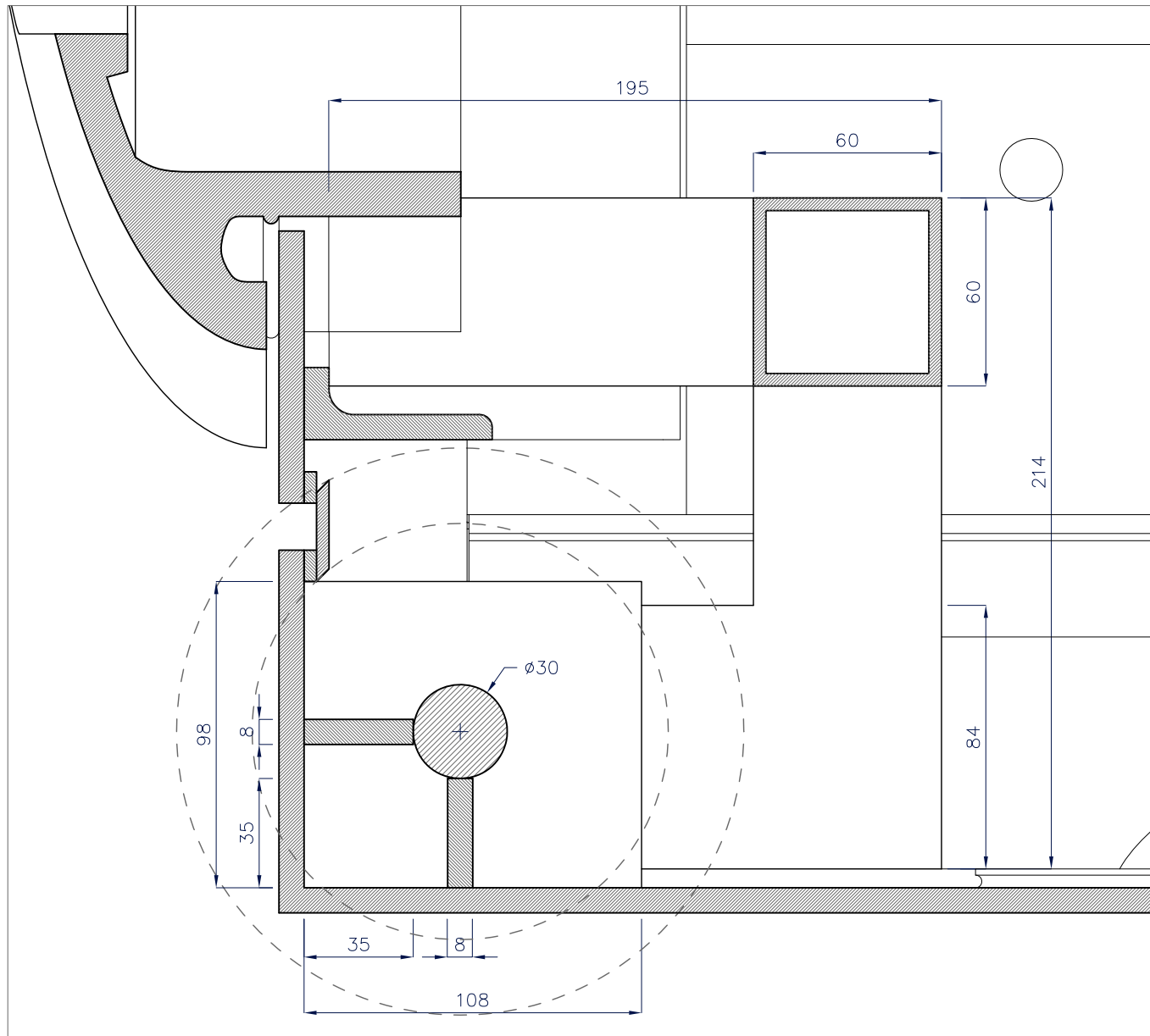
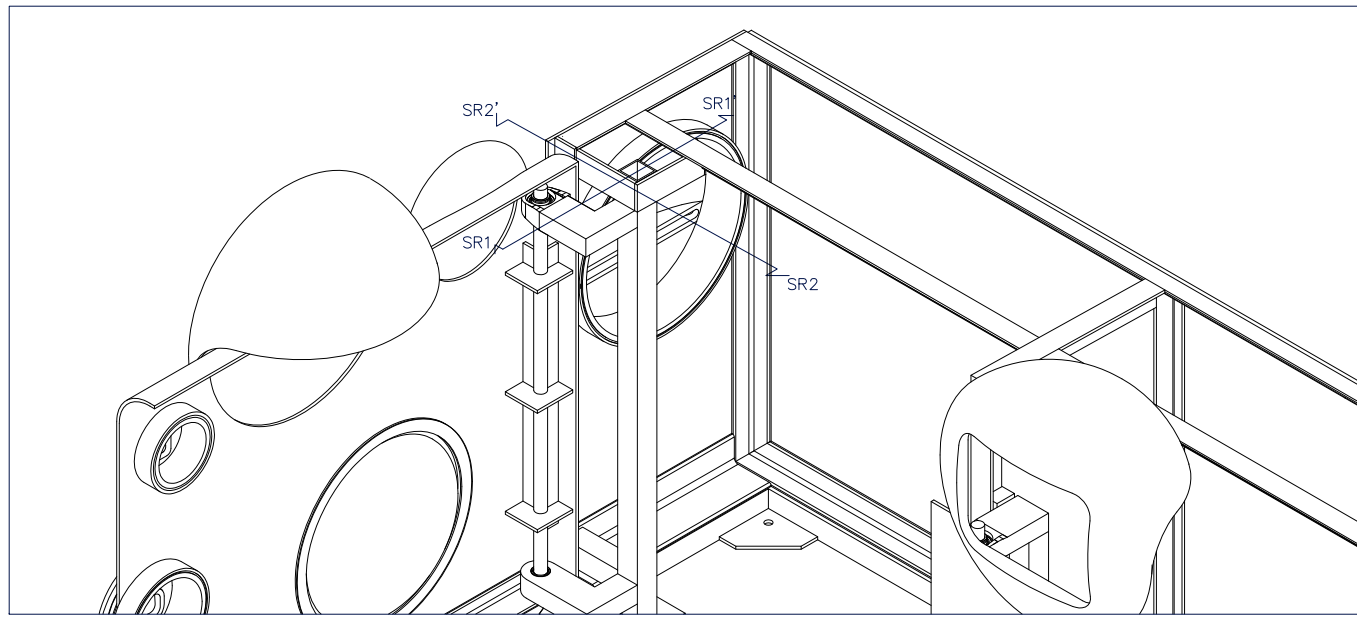

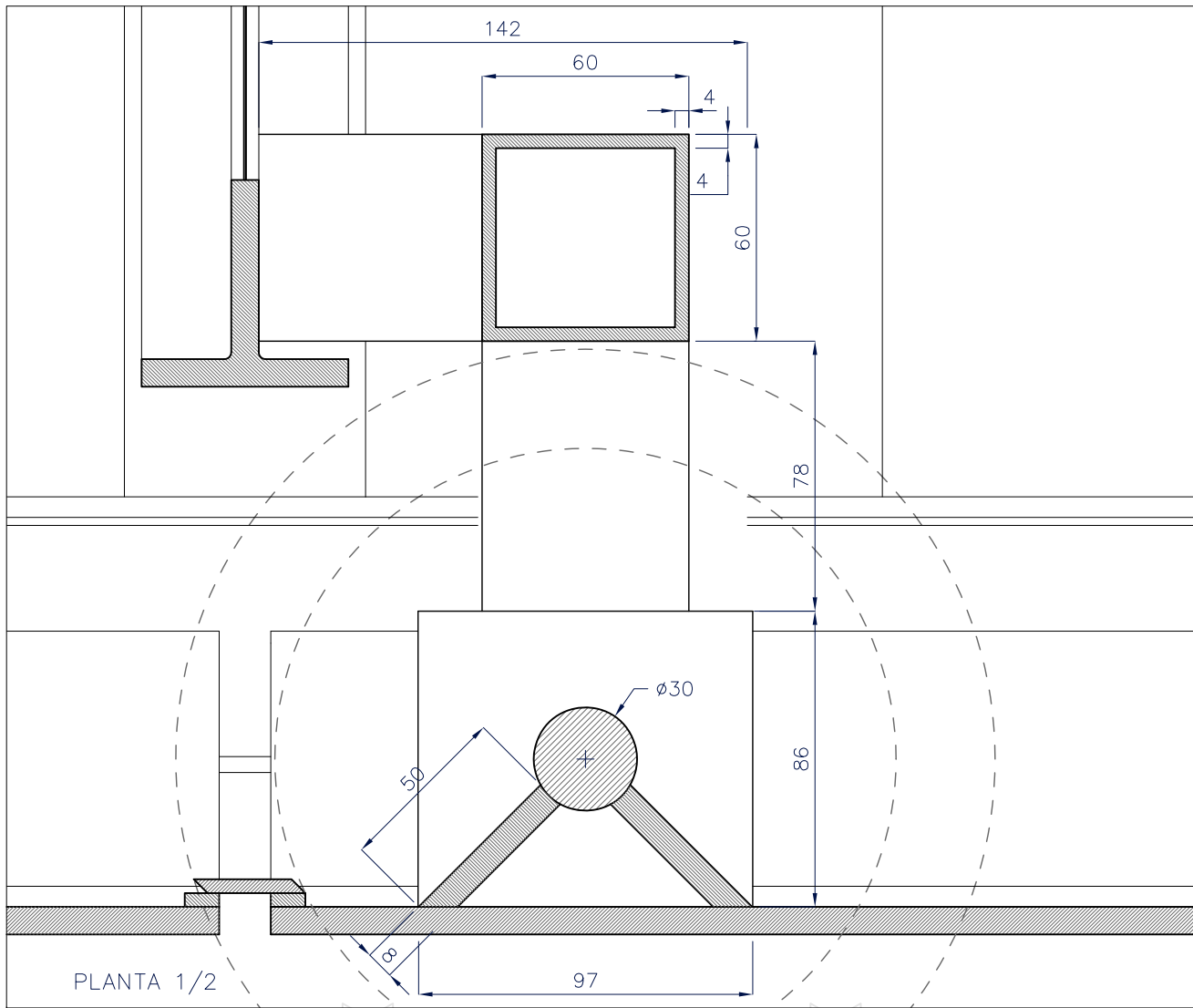
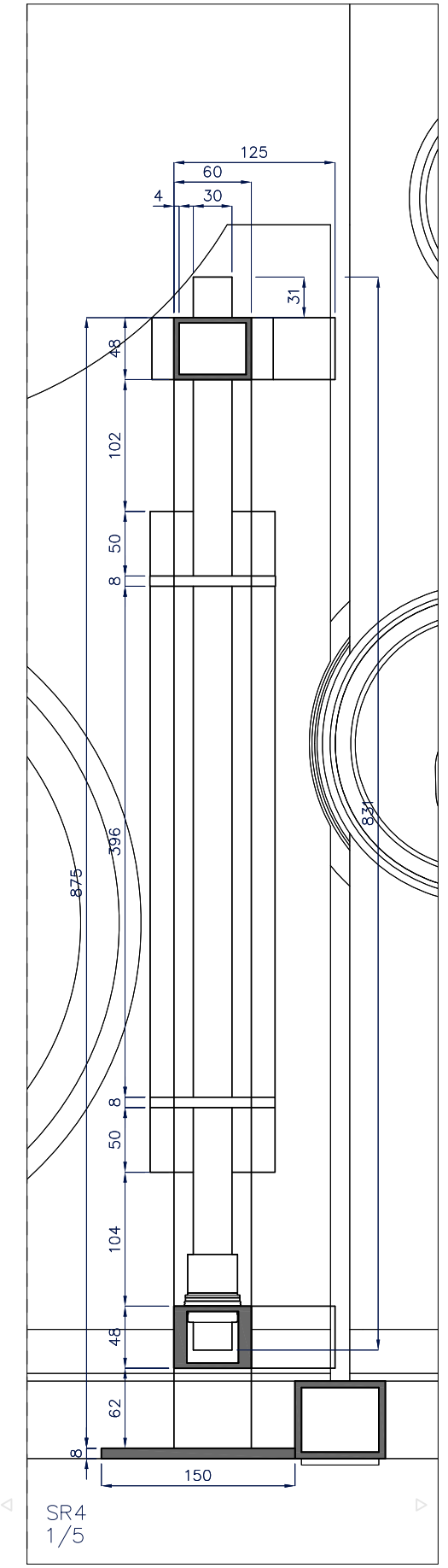
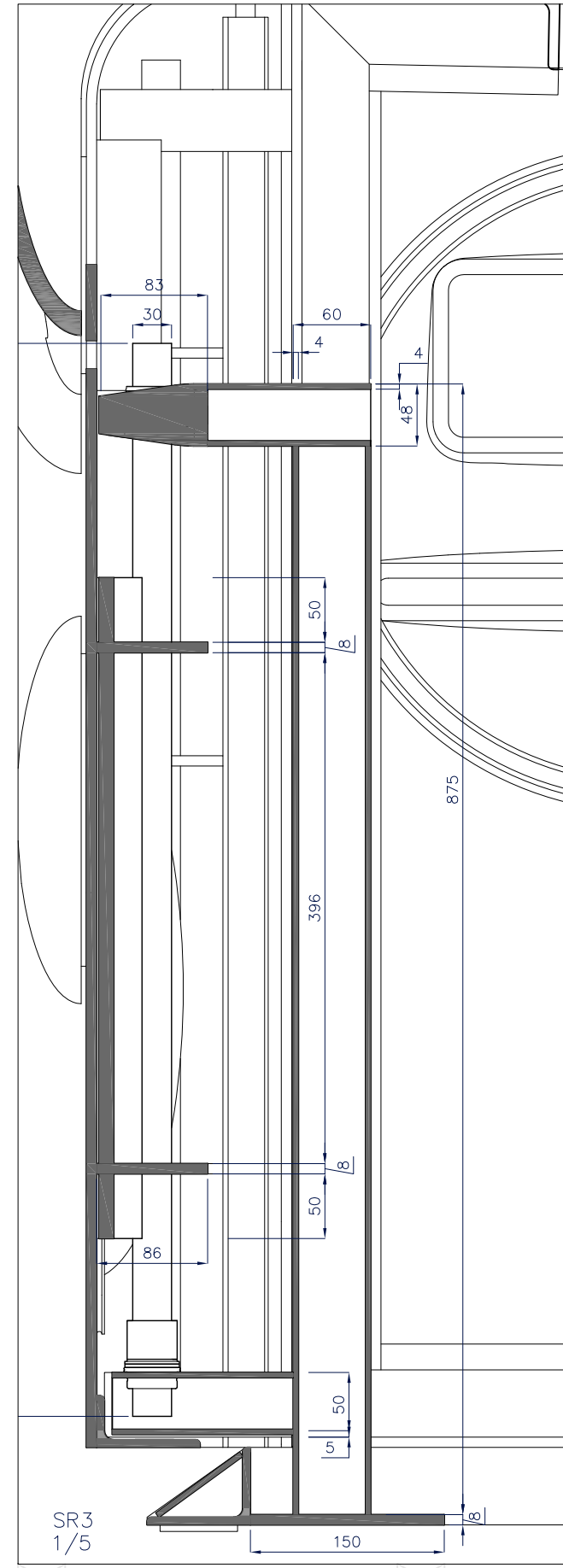
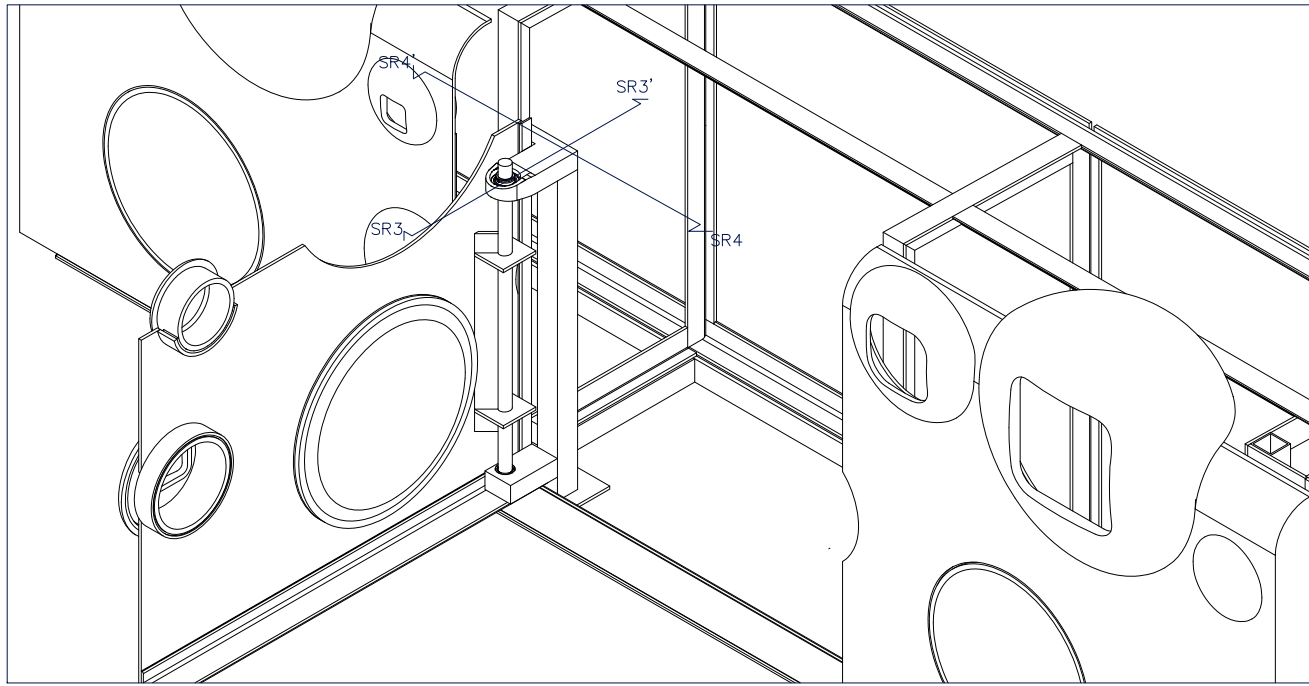

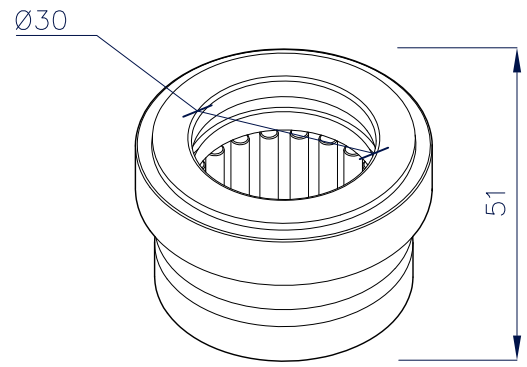

Rodamiento inferior tipo SKF mod. NKX 30 Z

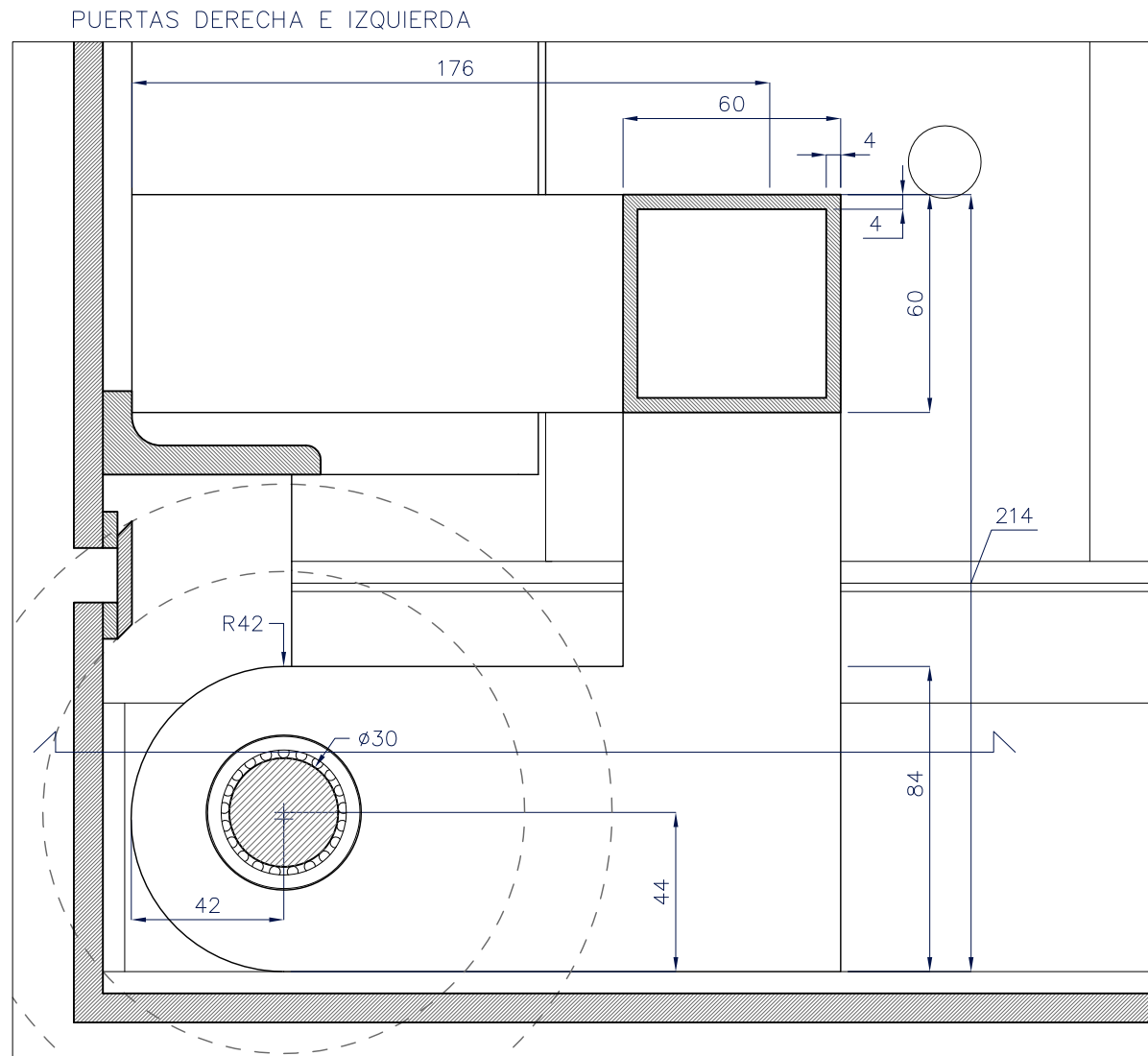

PLANTA

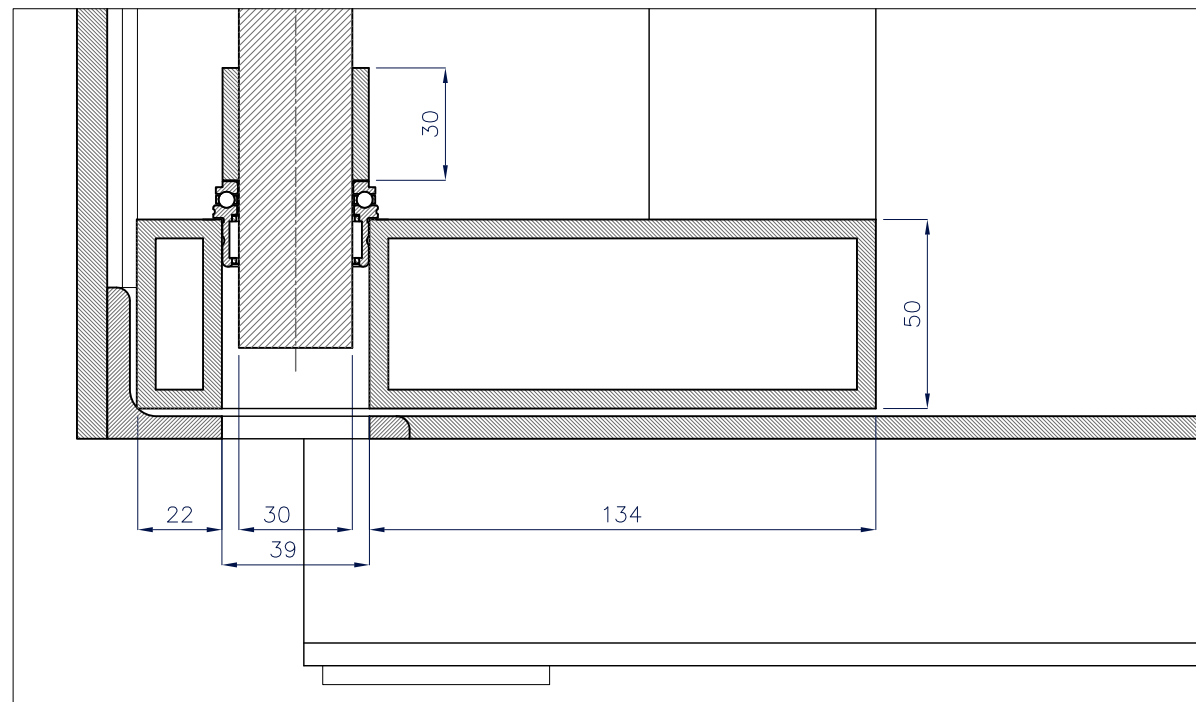

SECCIÓN

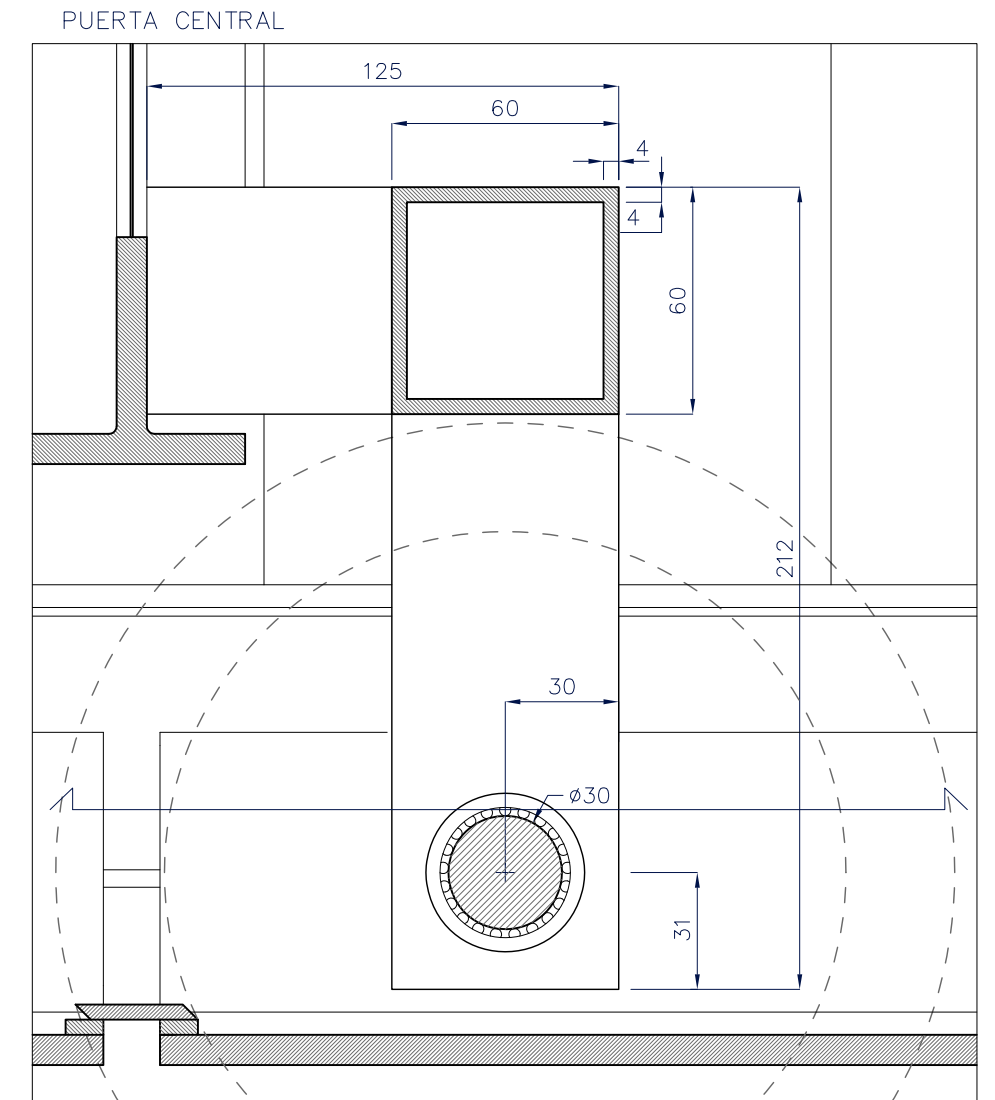

PLANTA

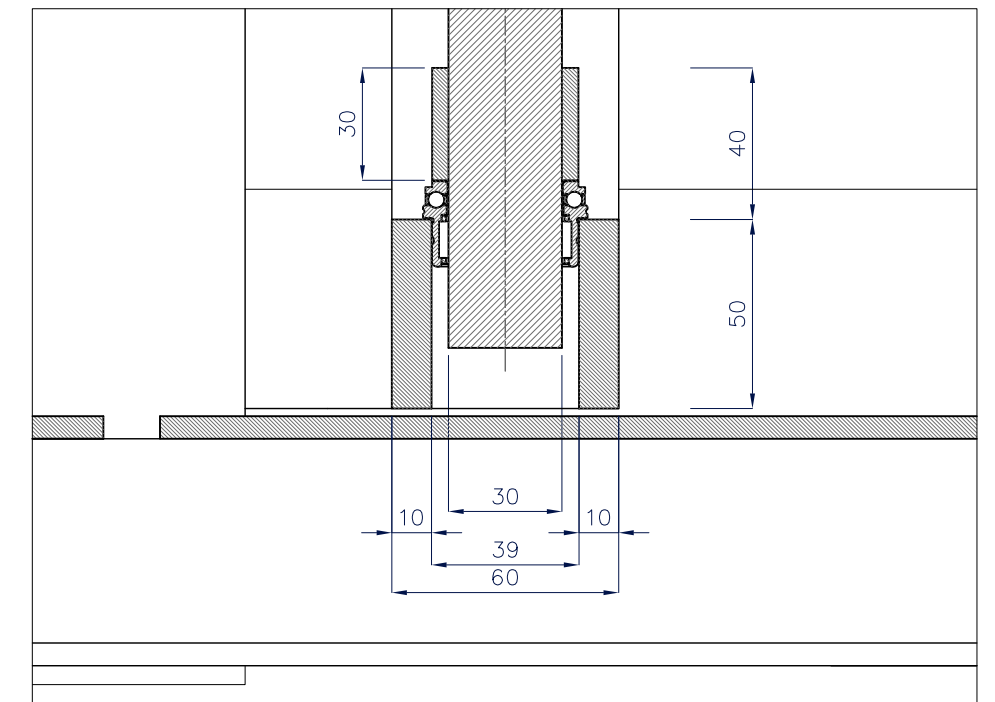

SECCIÓN

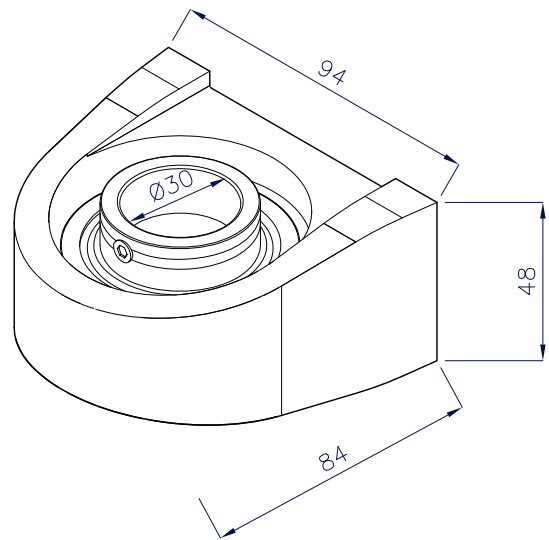

Rodamiento superior tipo SKF mod. SYFJ 30 TF

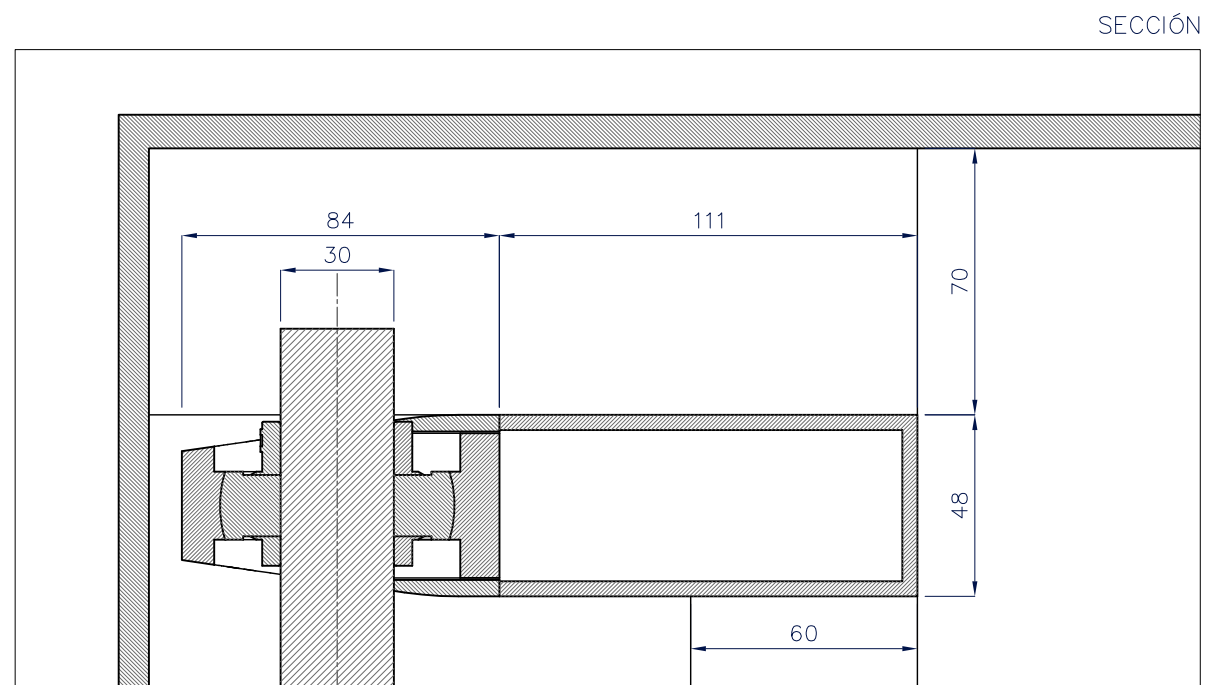
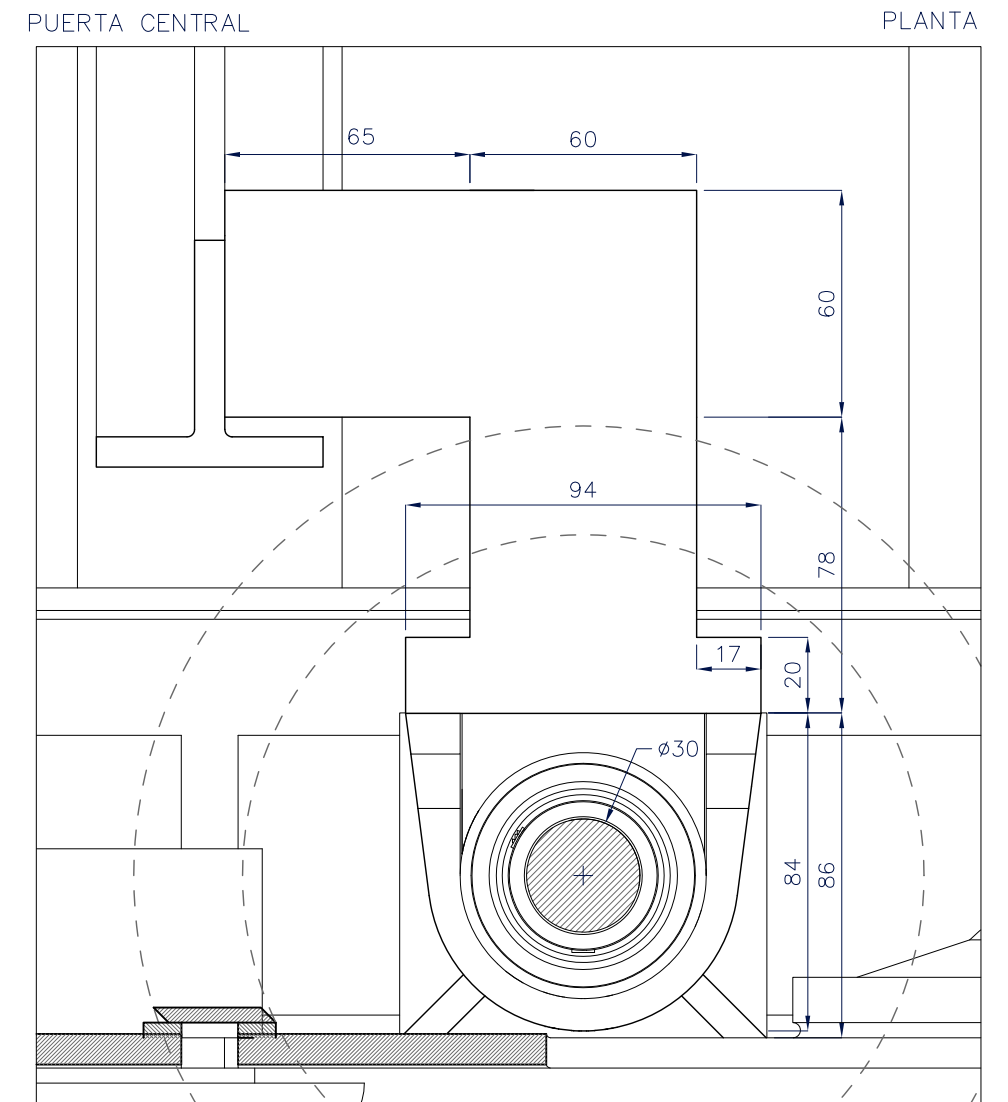
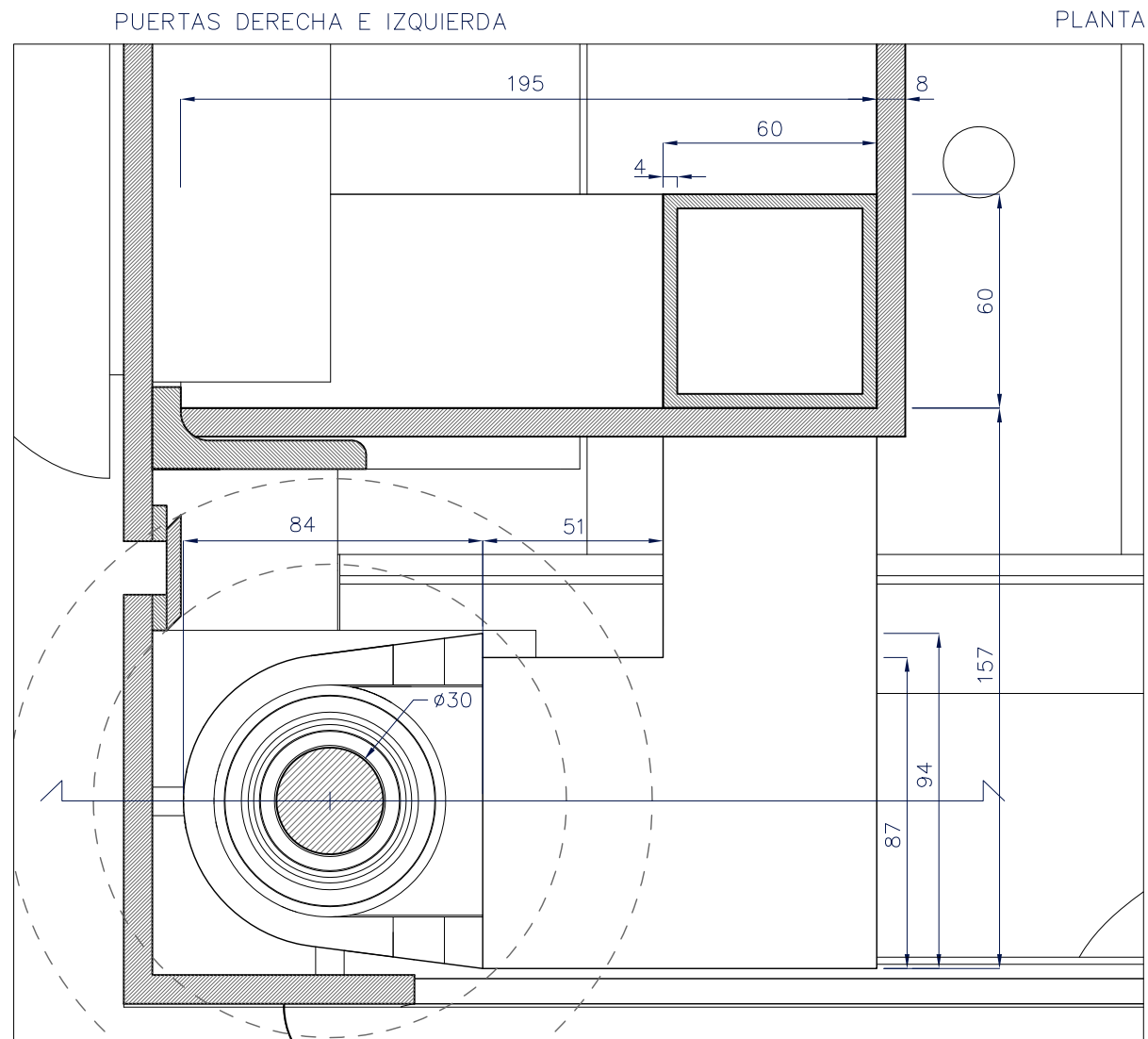

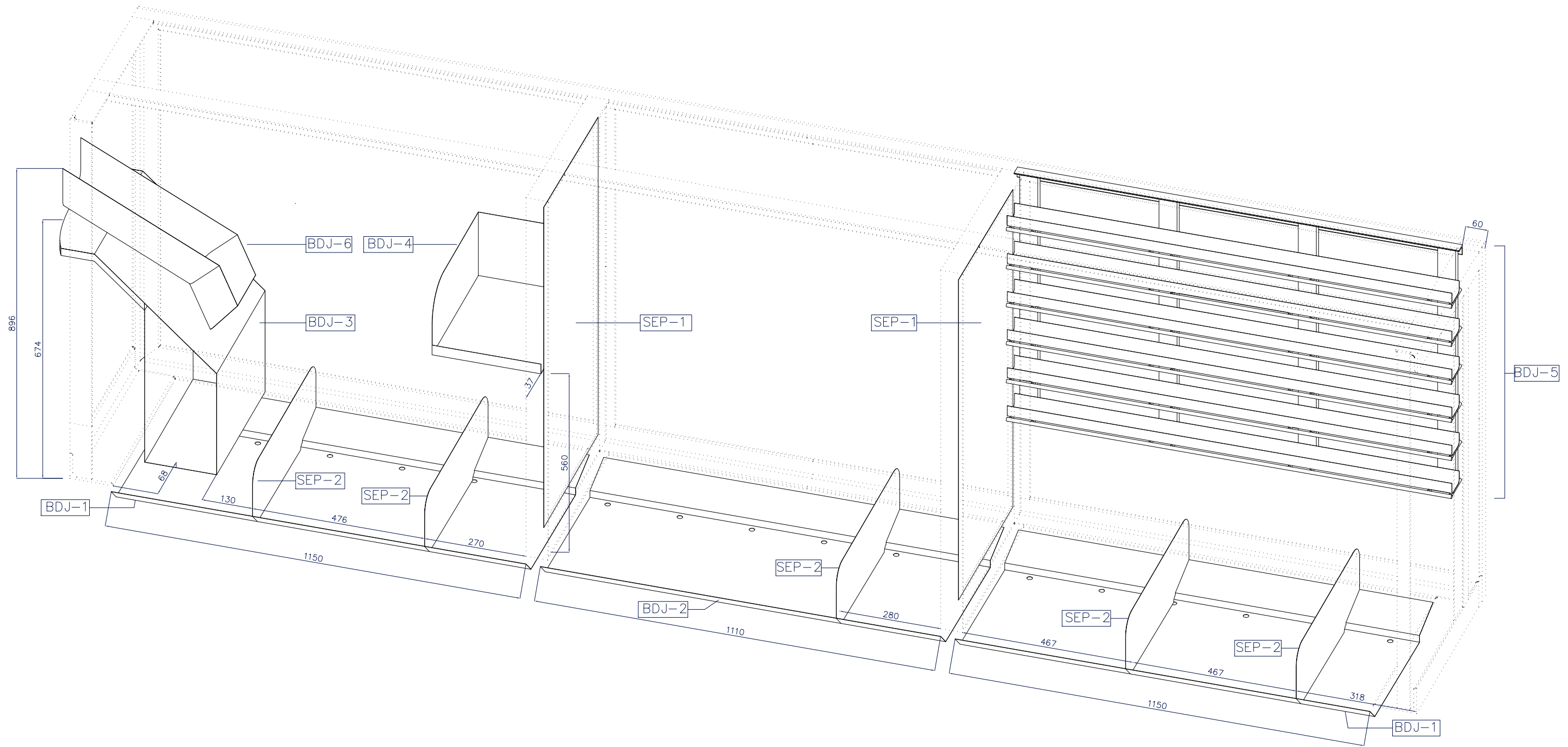

BDJ-1

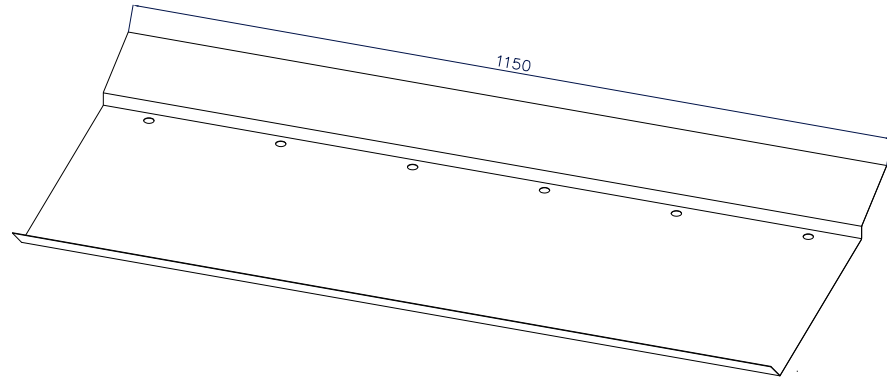

BDJ-2

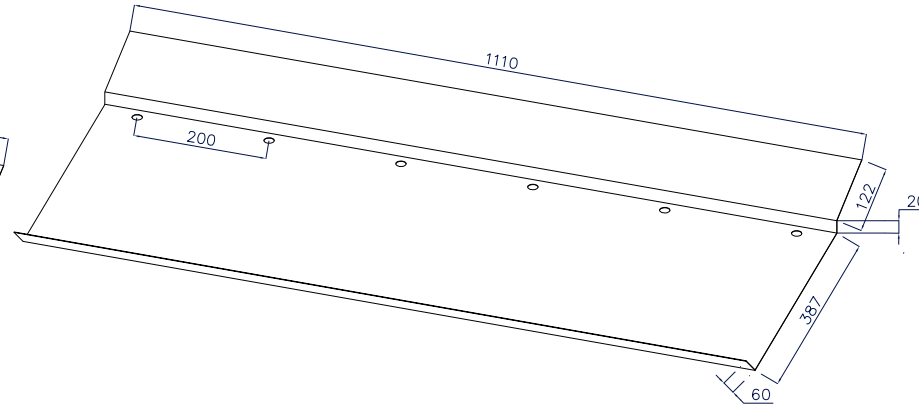

BDJ-3

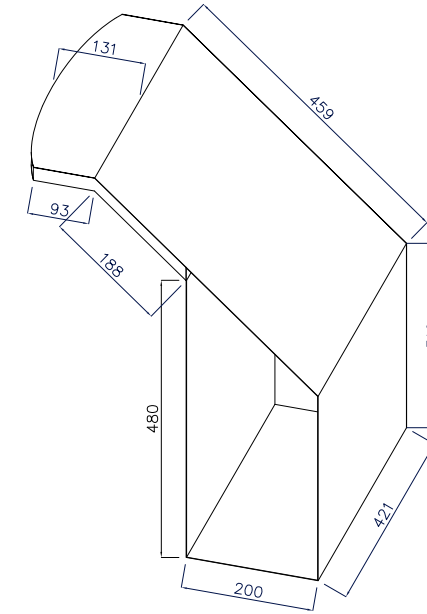

BDJ-4

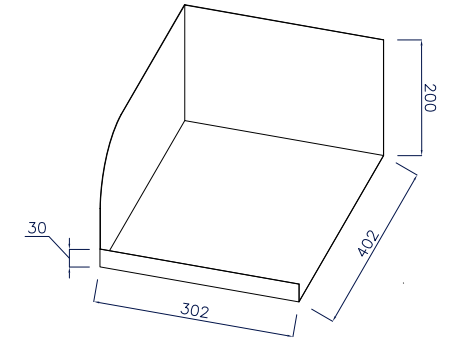

BDJ-6

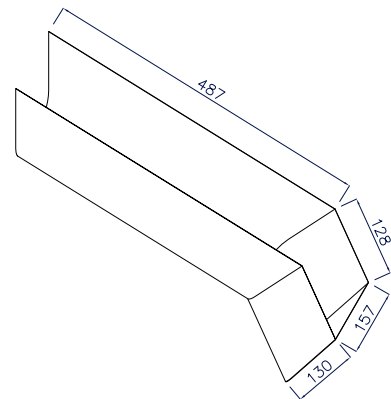

BDJ-5

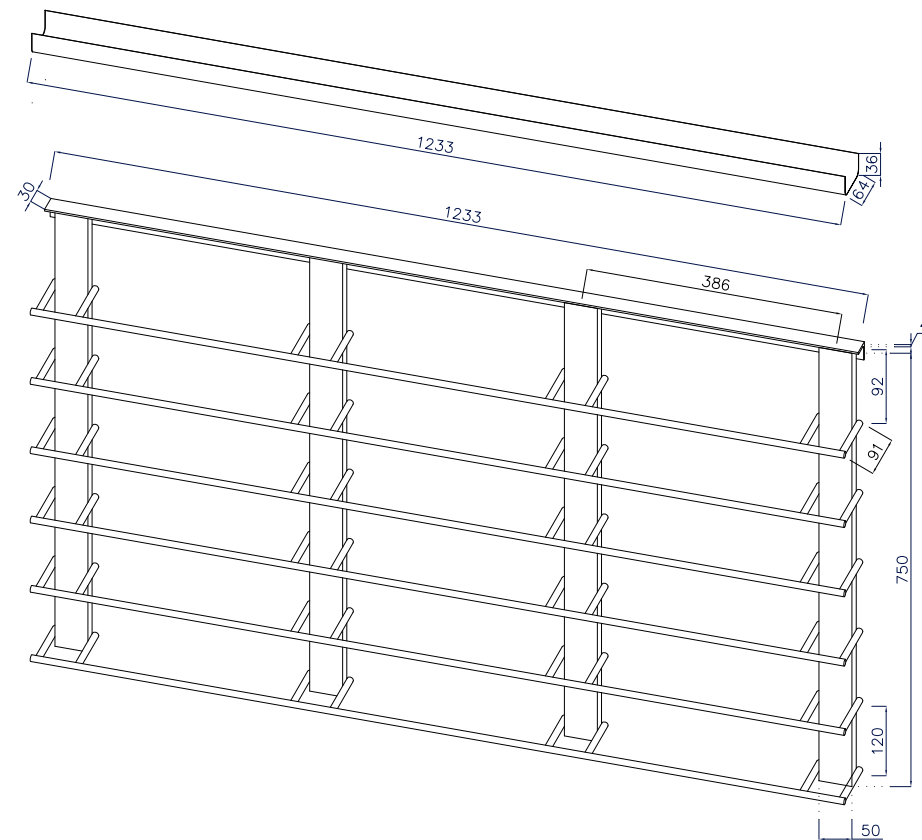

SEP-1

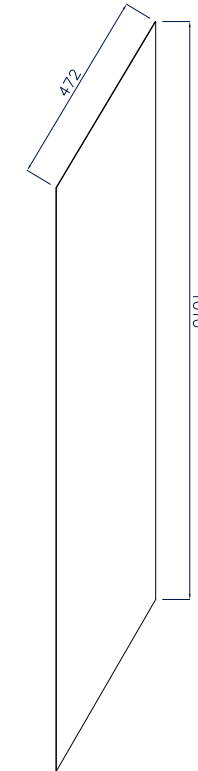

SEP-2

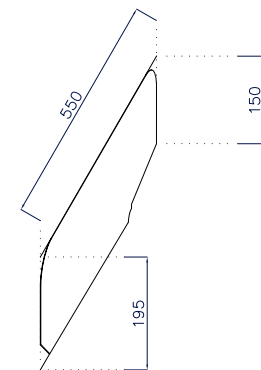









SECCIÓN TRANSVERSAL 7

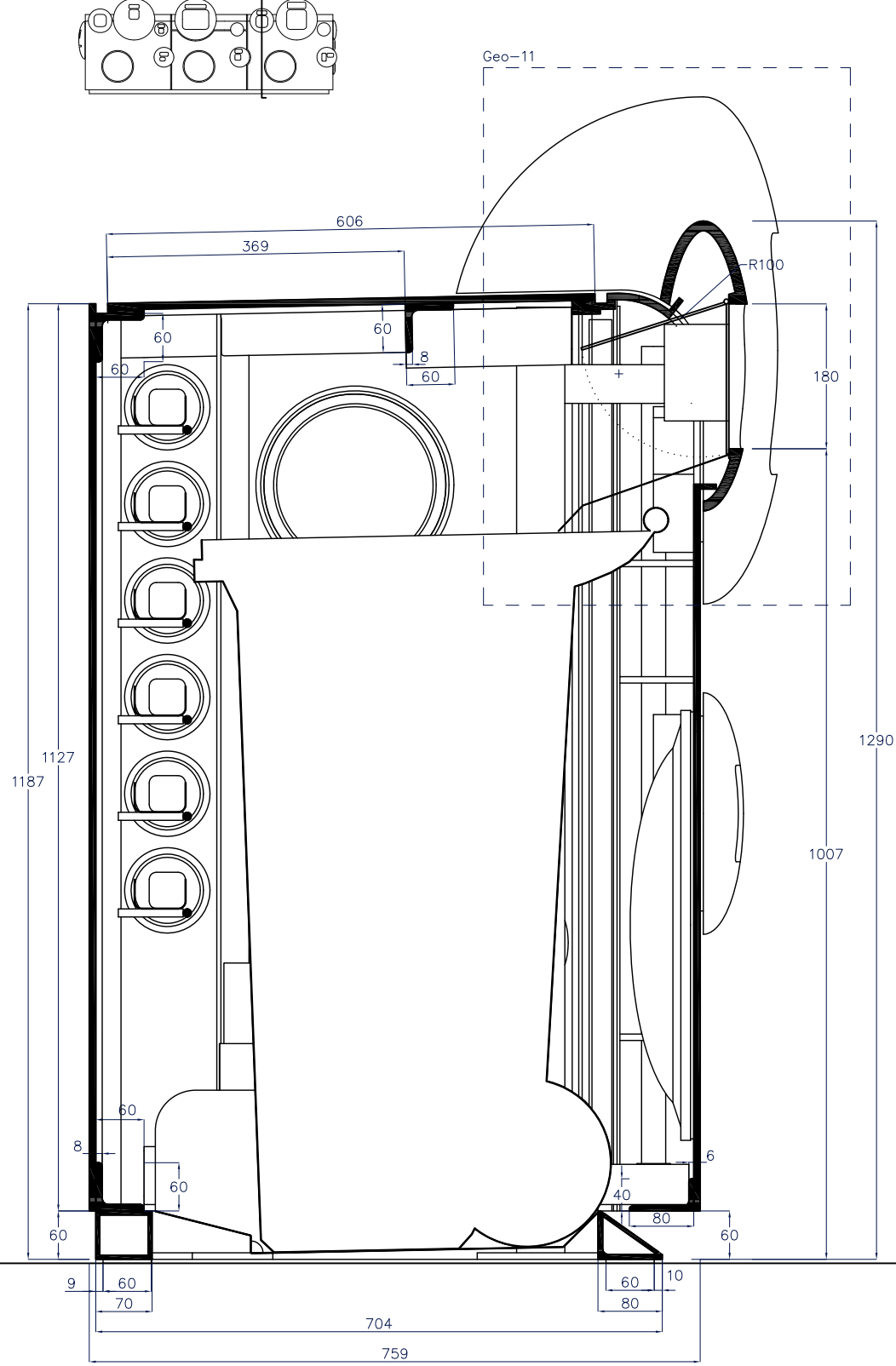

SECCIÓN TRANSVERSAL 8

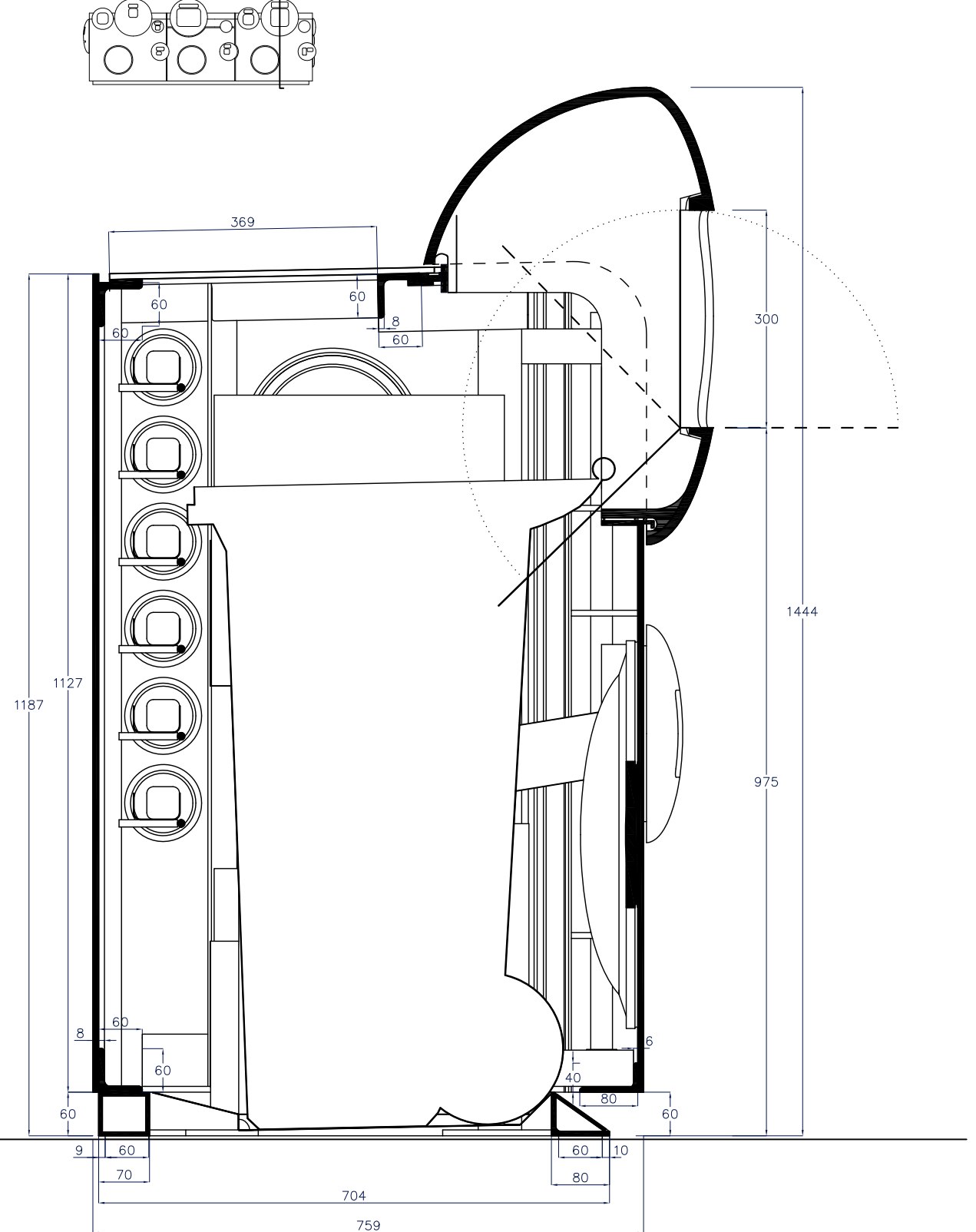

SECCIÓN TRANSVERSAL 9

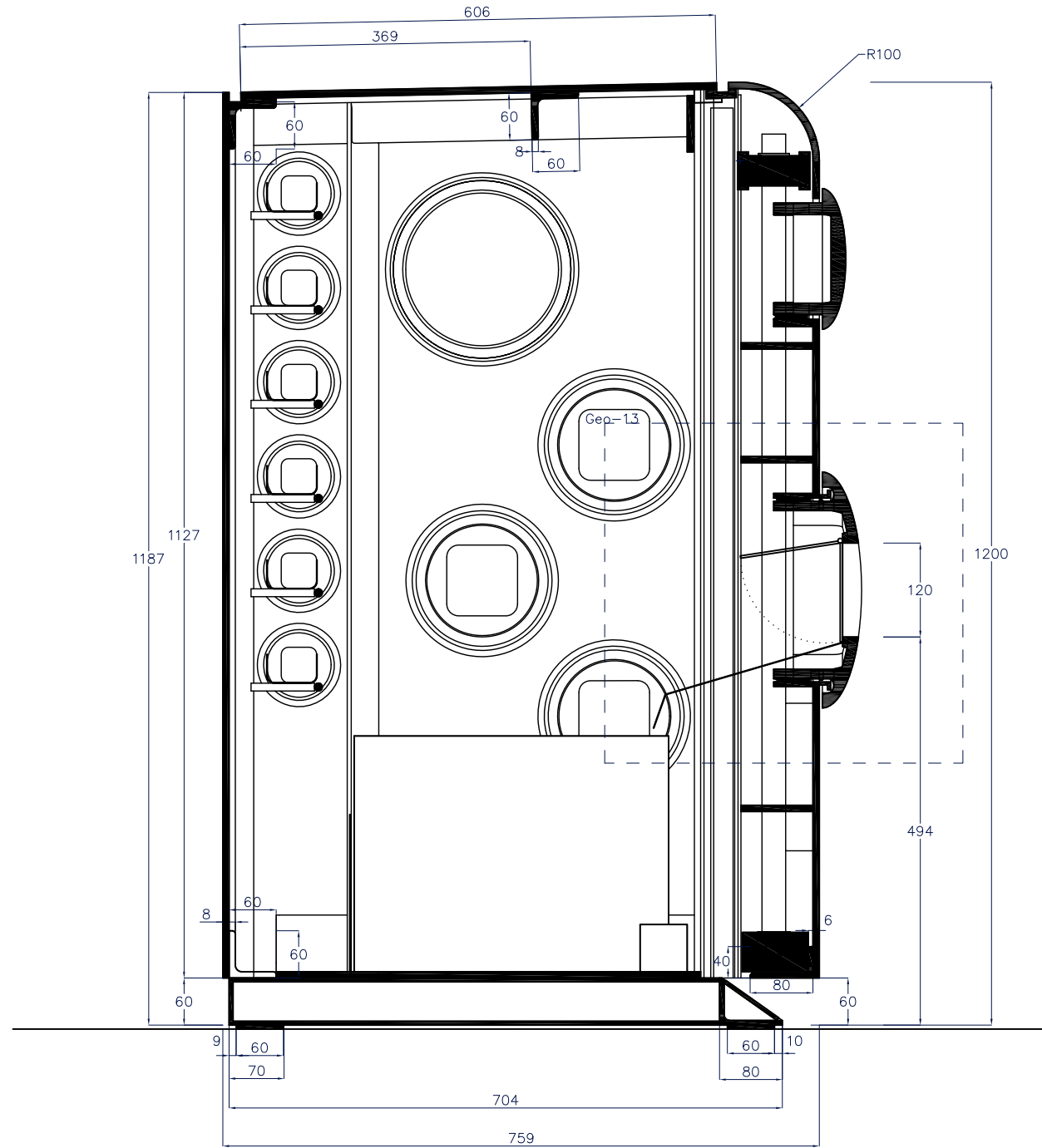
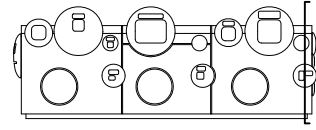

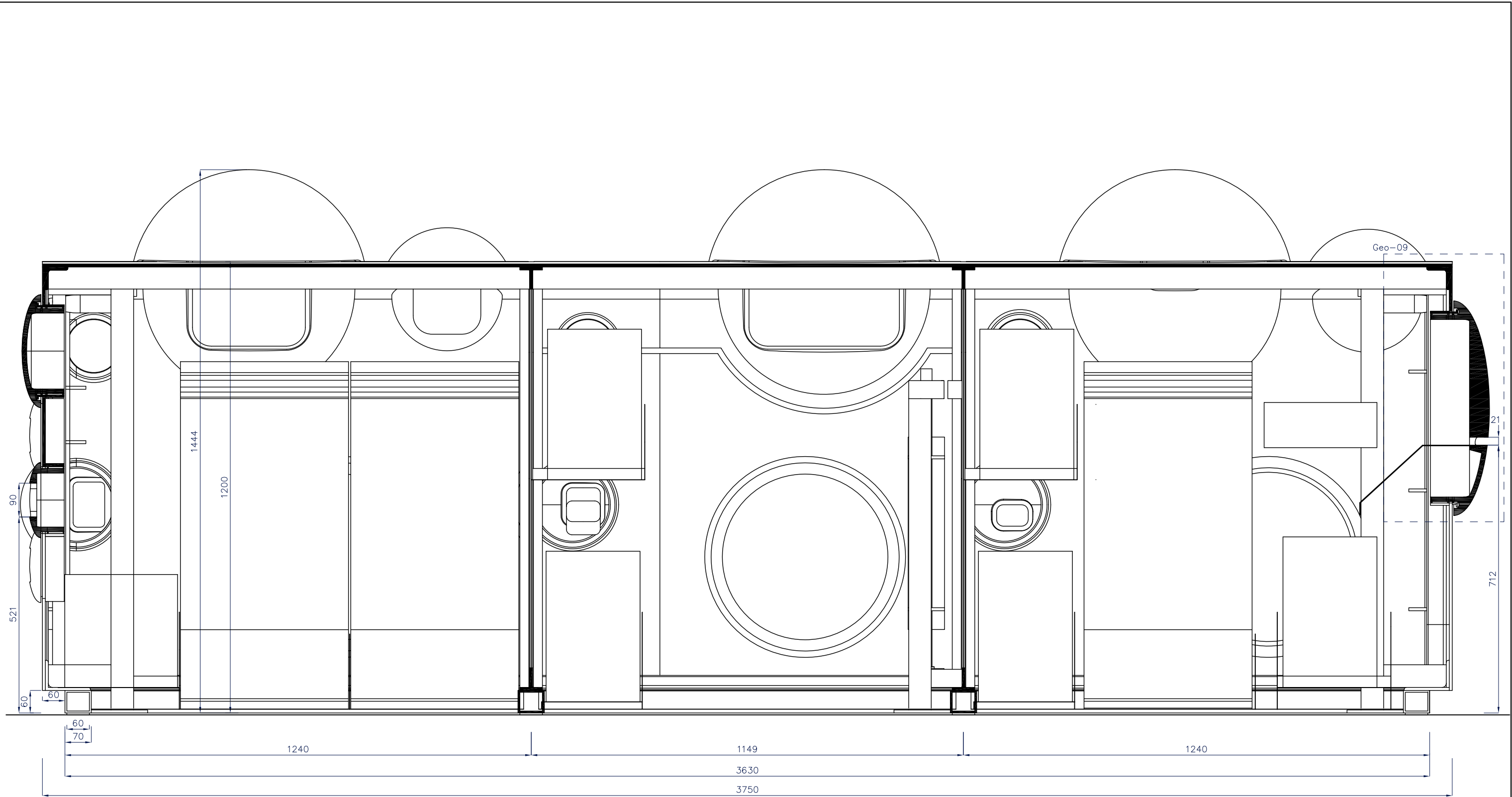

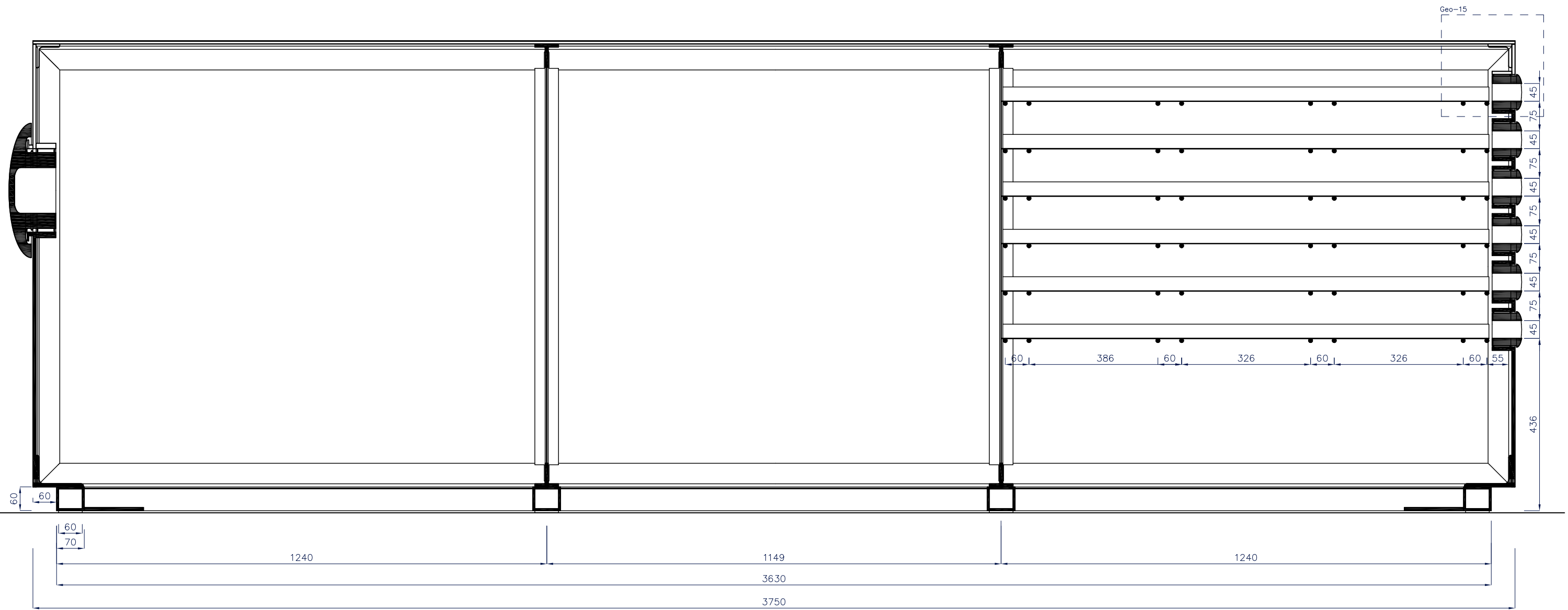

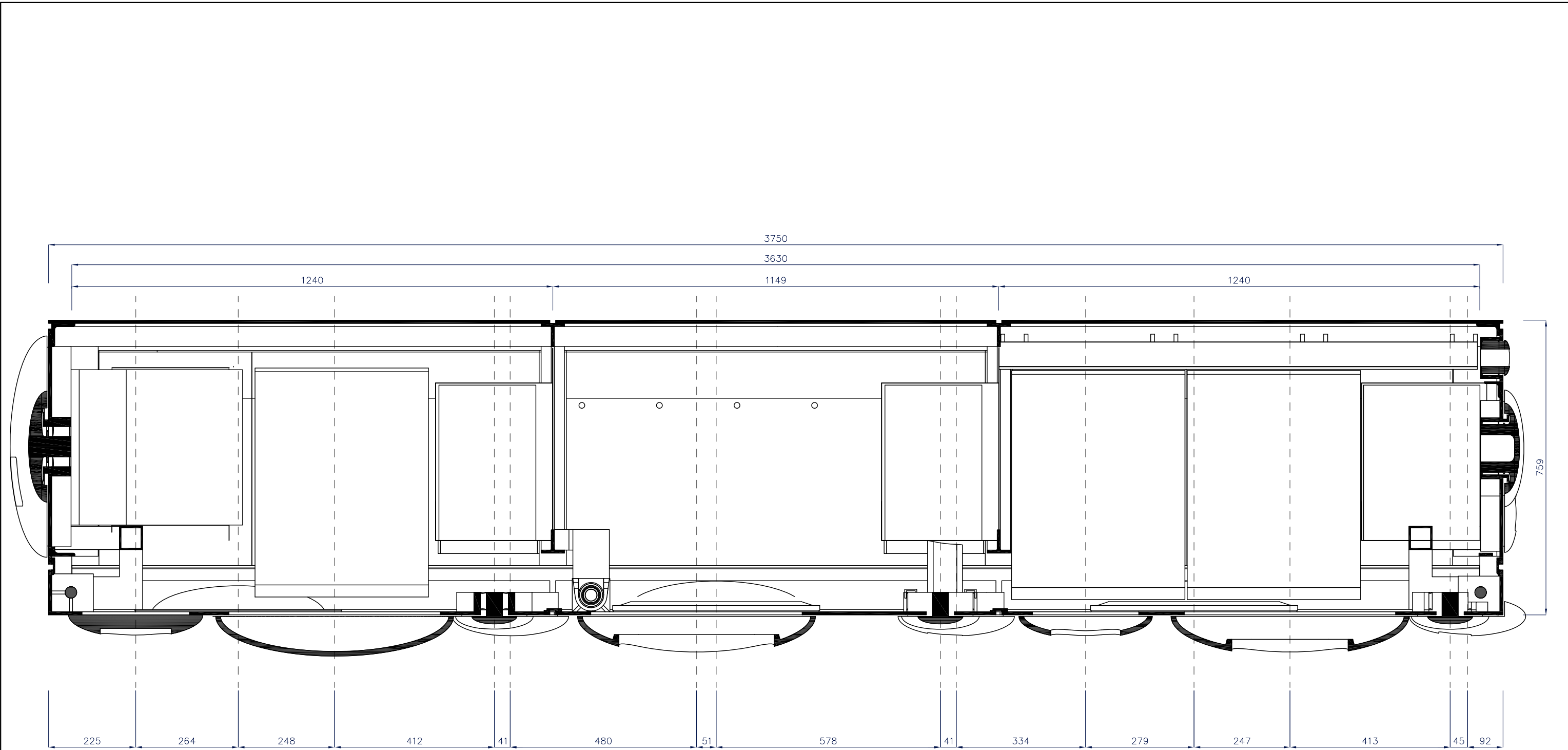



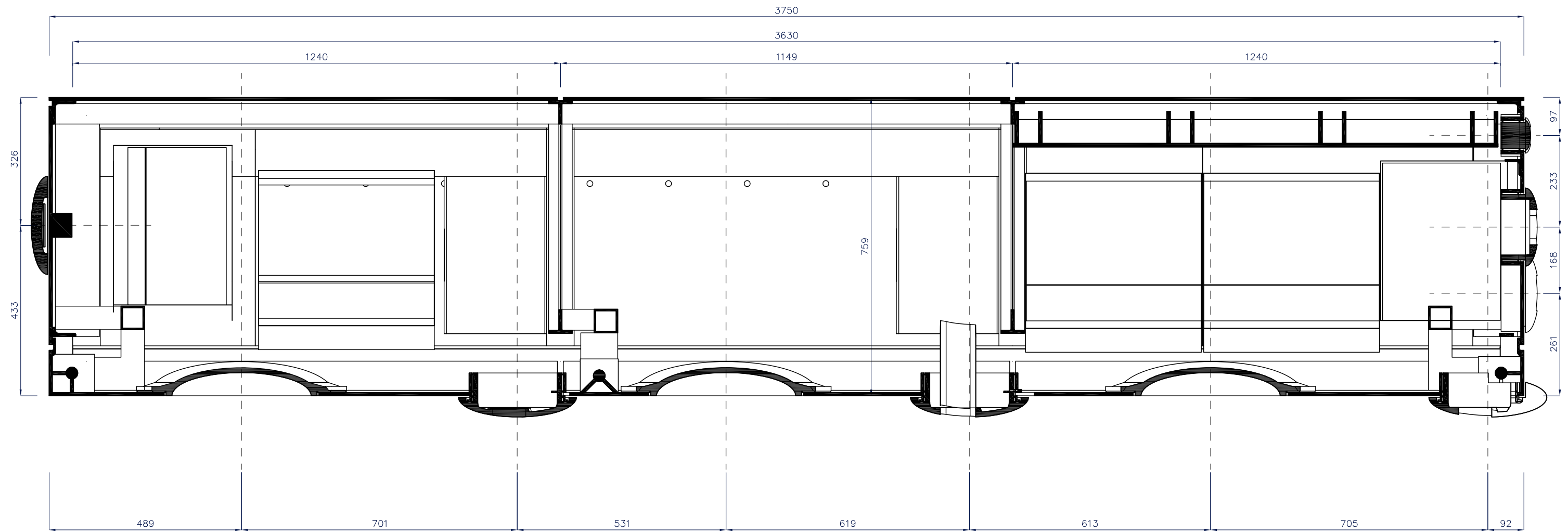

ALZADO POSTERIOR

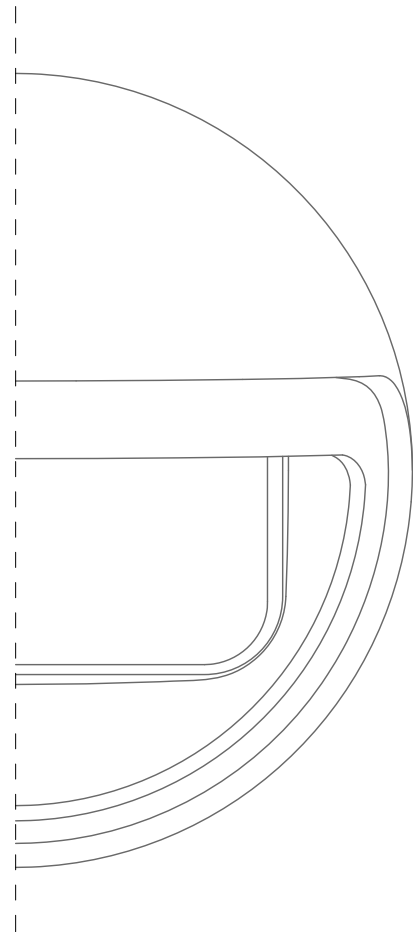

ALZADO FRONTAL

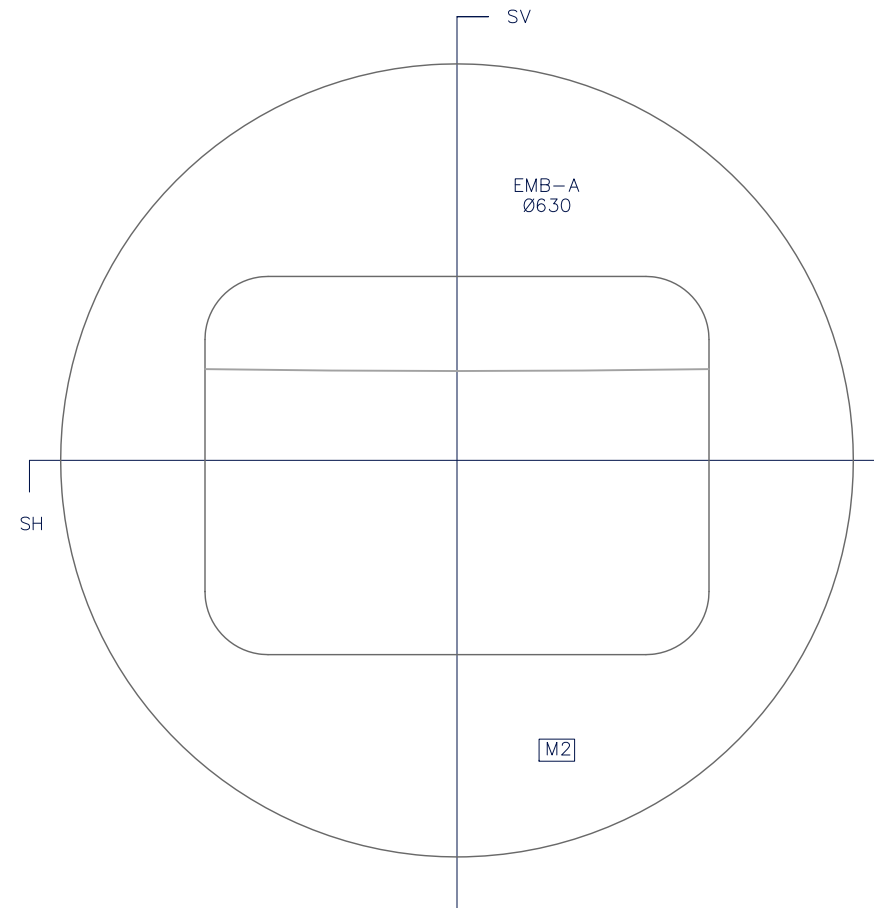

SECCIÓN VERTICAL

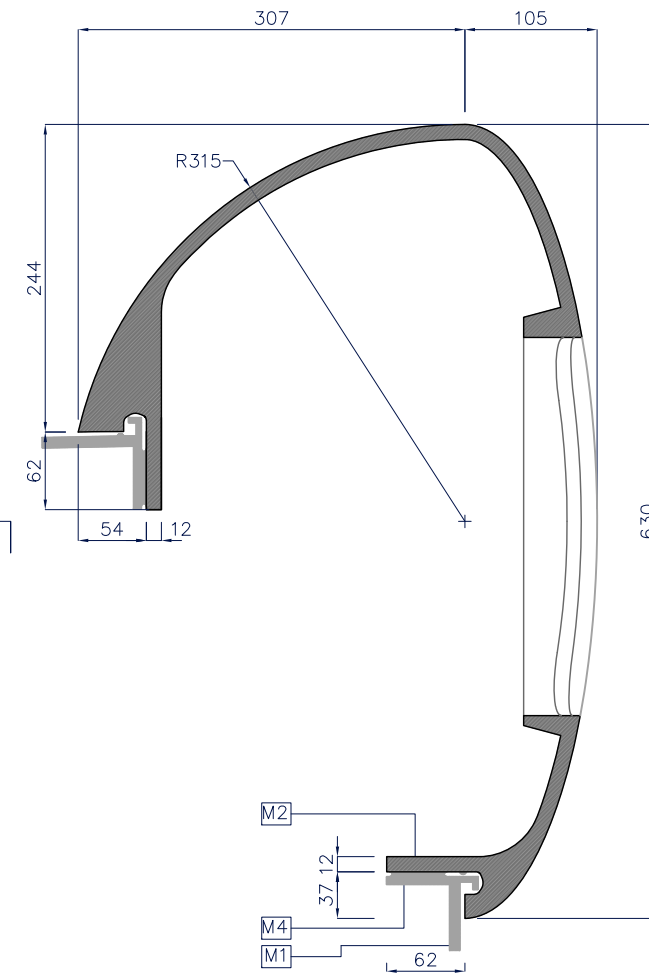

SECCIÓN HORIZONTAL

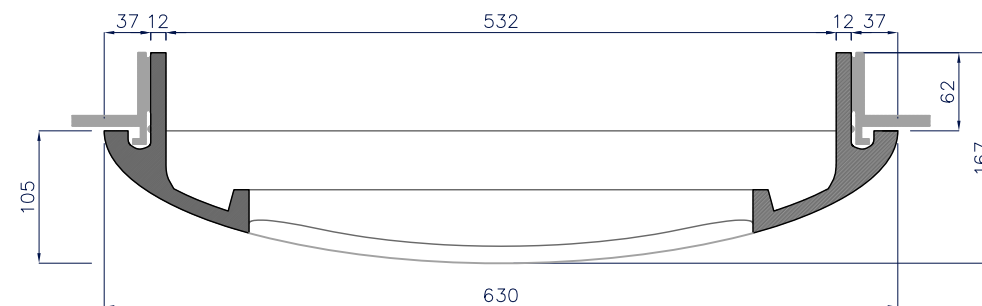

Materiales	
M1	Acero inoxidable S316L
M2	Fundición de aluminio anodizado color
M3	Fundición de aluminio anodizado natural
M4	Neopreno

E 1/8

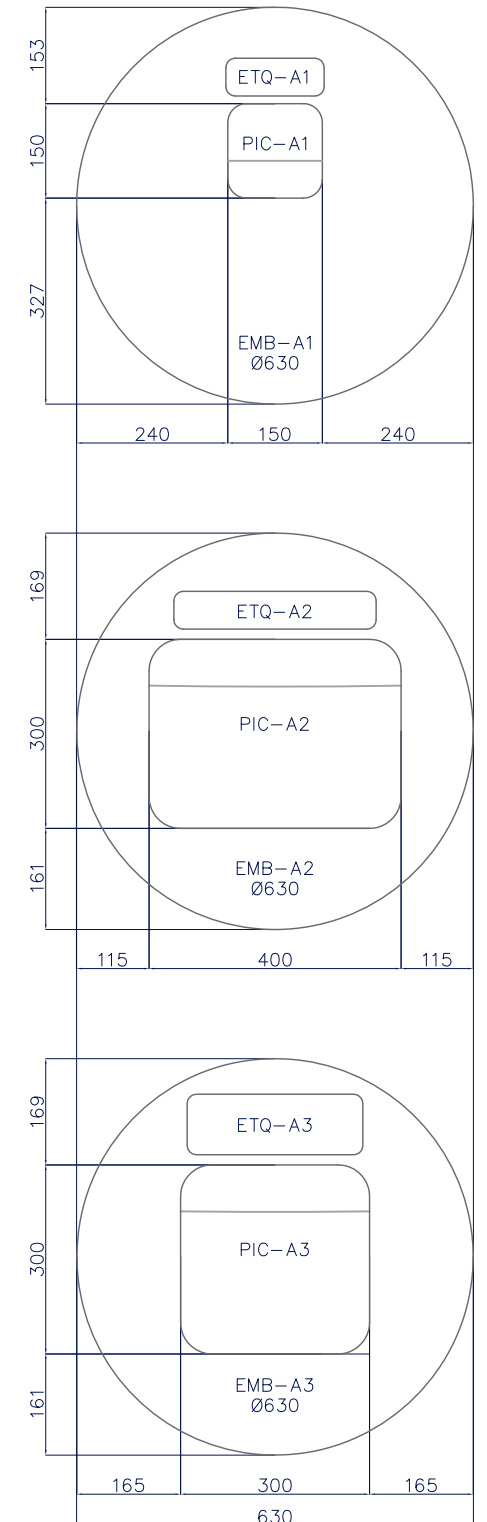

E 1/12

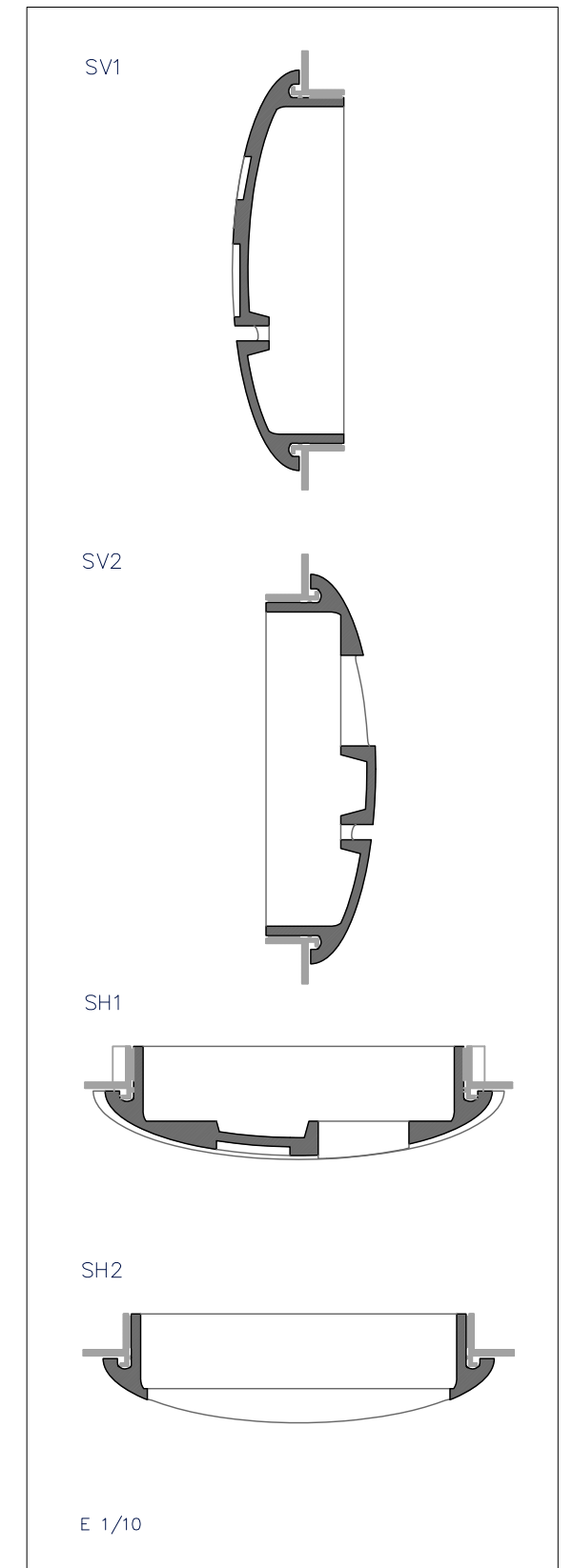
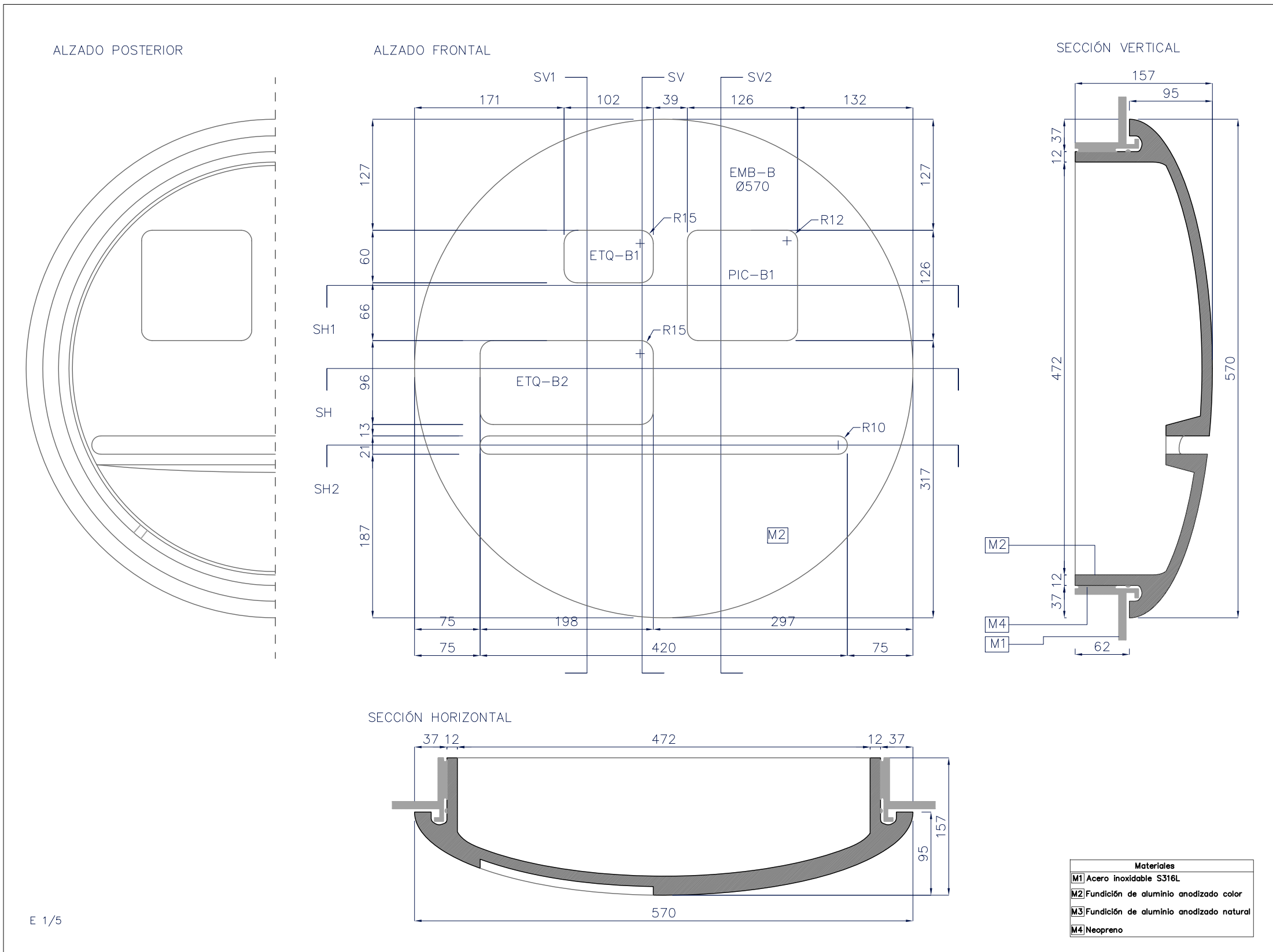

ALZADO POSTERIOR

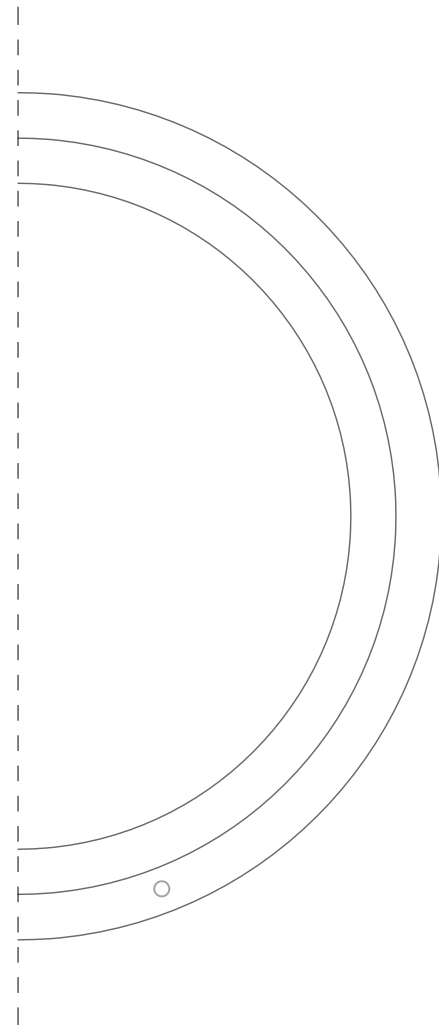

ALZADO FRONTAL

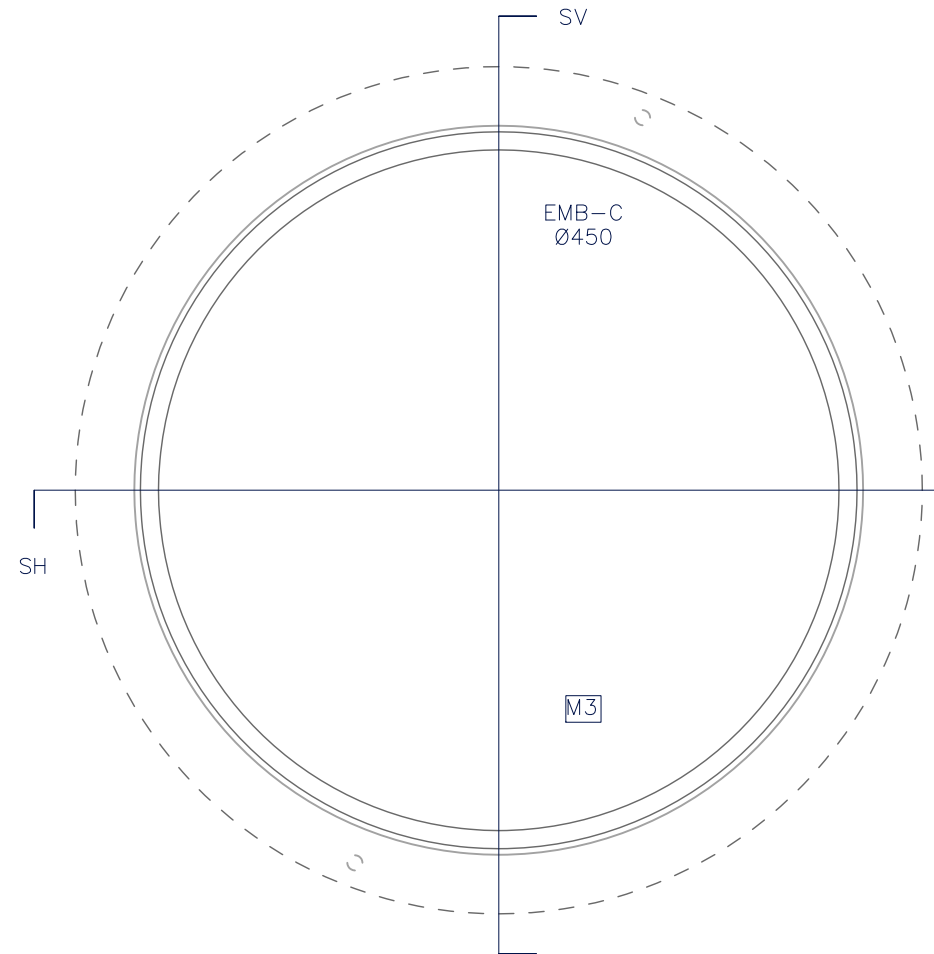

SECCIÓN VERTICAL

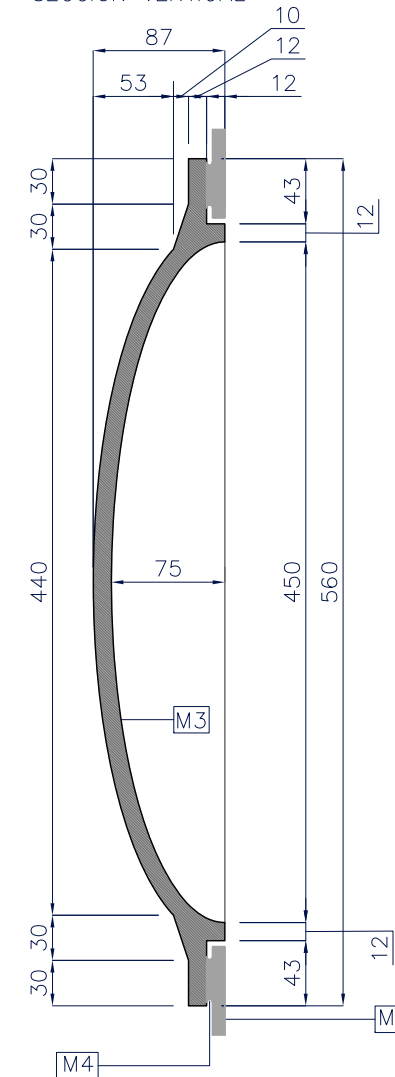

SECCIÓN HORIZONTAL

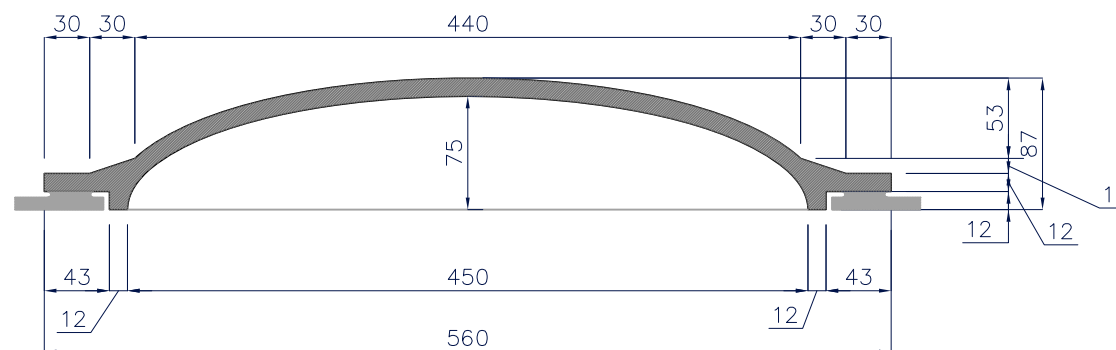

Materiales	
M1	Acero inoxidable S316L
M2	Fundición de aluminio anodizado color
M3	Fundición de aluminio anodizado natural
M4	Neopreno

ALZADO POSTERIOR

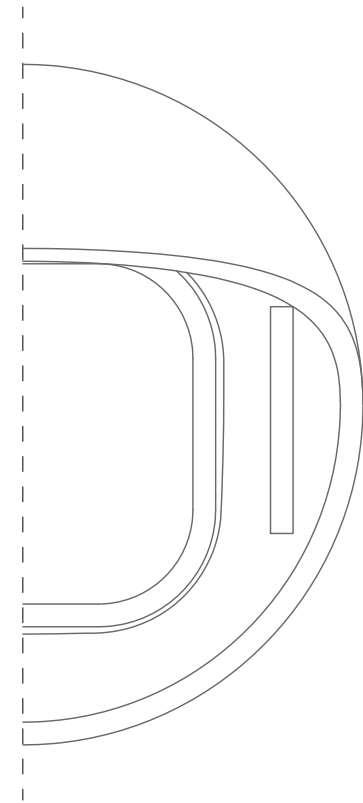

ALZADO FRONTAL

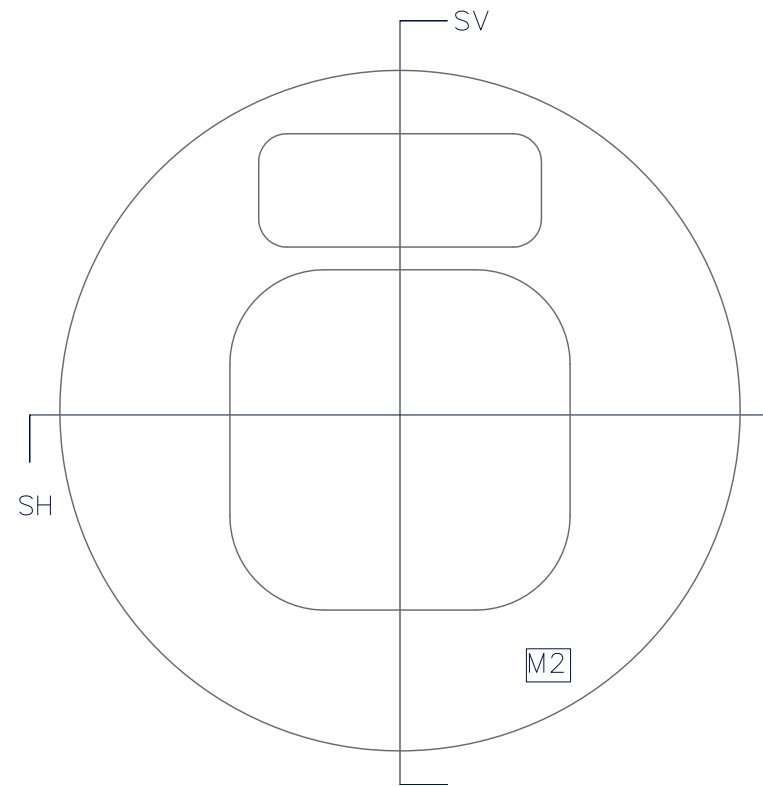

SECCIÓN VERTICAL

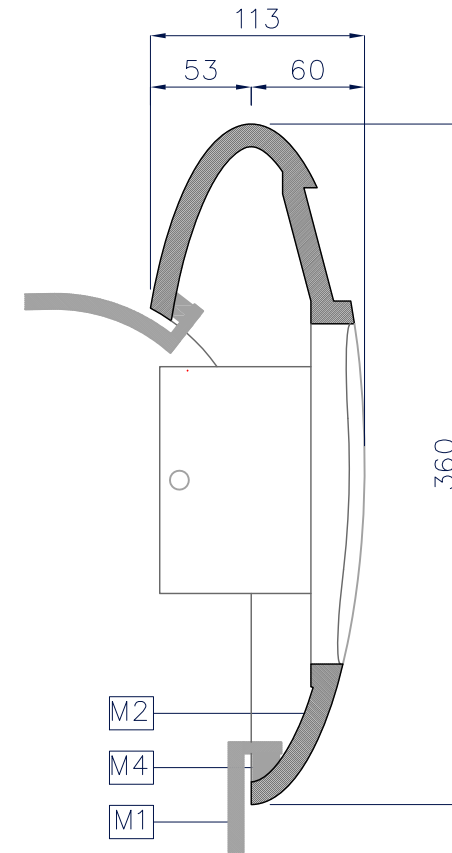

SECCIÓN HORIZONTAL

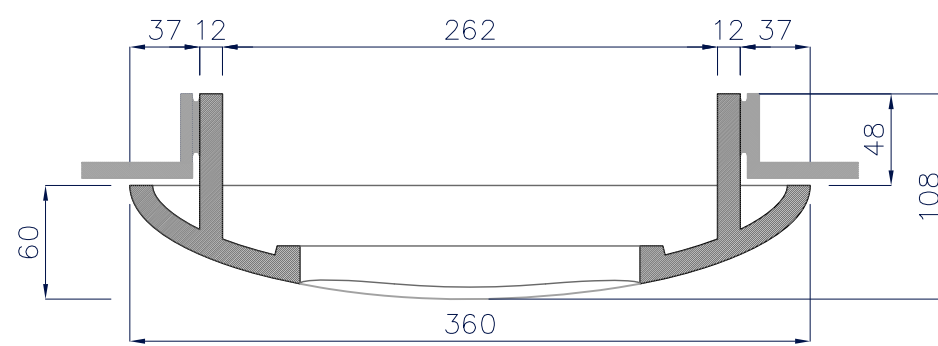

Materiales	
M1	Acero inoxidable S316L
M2	Fundición de aluminio anodizado color
M3	Fundición de aluminio anodizado natural
M4	Neopreno

E 1/4

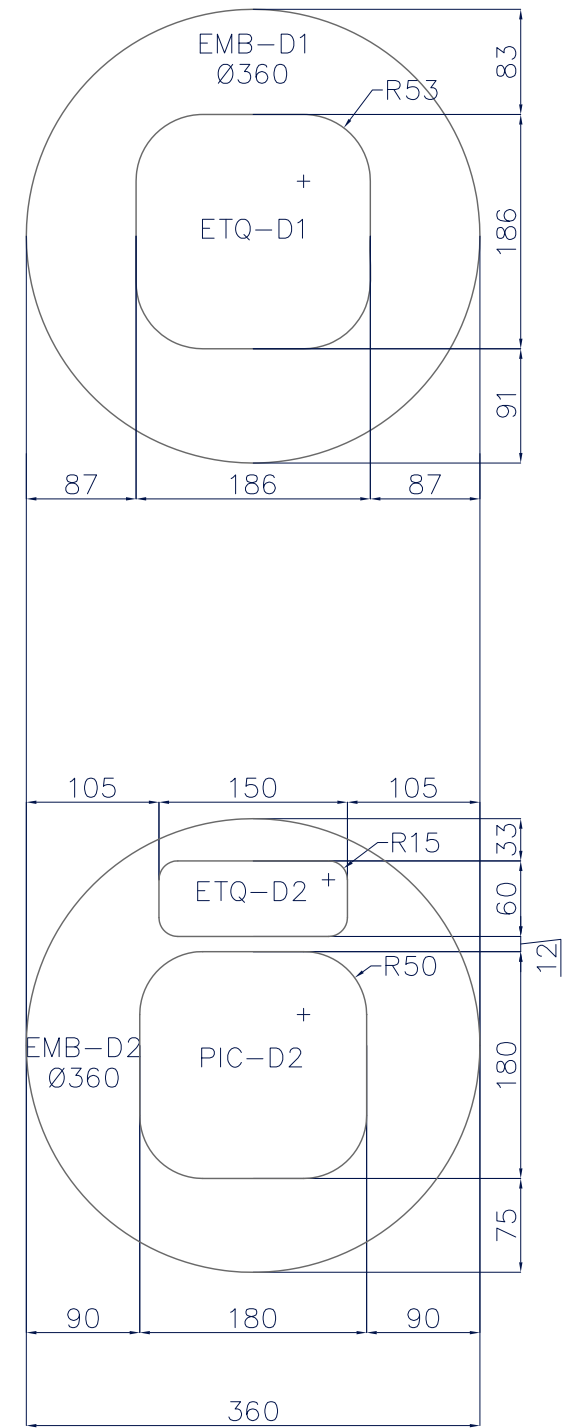

E 1/6

VISTA POSTERIOR

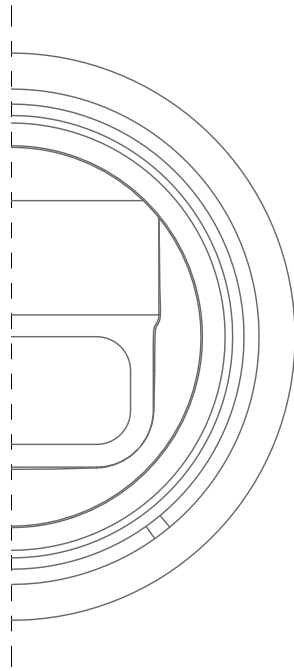

ALZADO FRONTAL

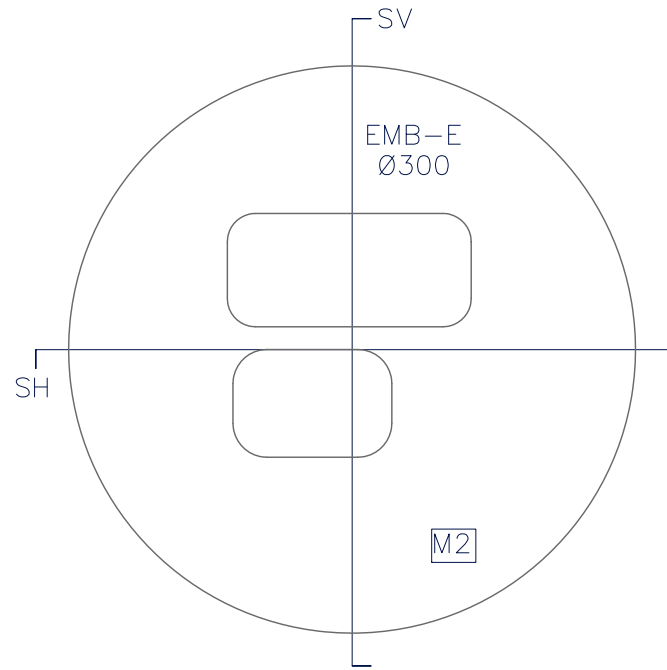

SECCIÓN VERTICAL

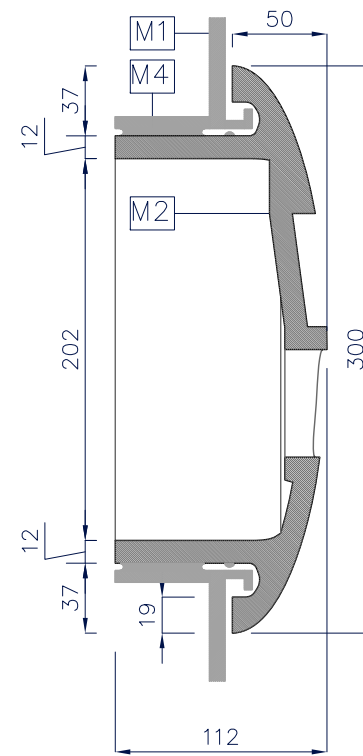

SECCIÓN HORIZONTAL

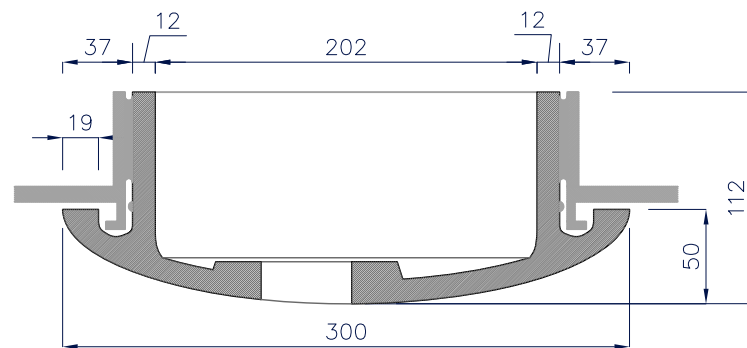

Materiales	
M1	Acero inoxidable S316L
M2	Fundición de aluminio anodizado color
M3	Fundición de aluminio anodizado natural
M4	Neopreno

E 1/4

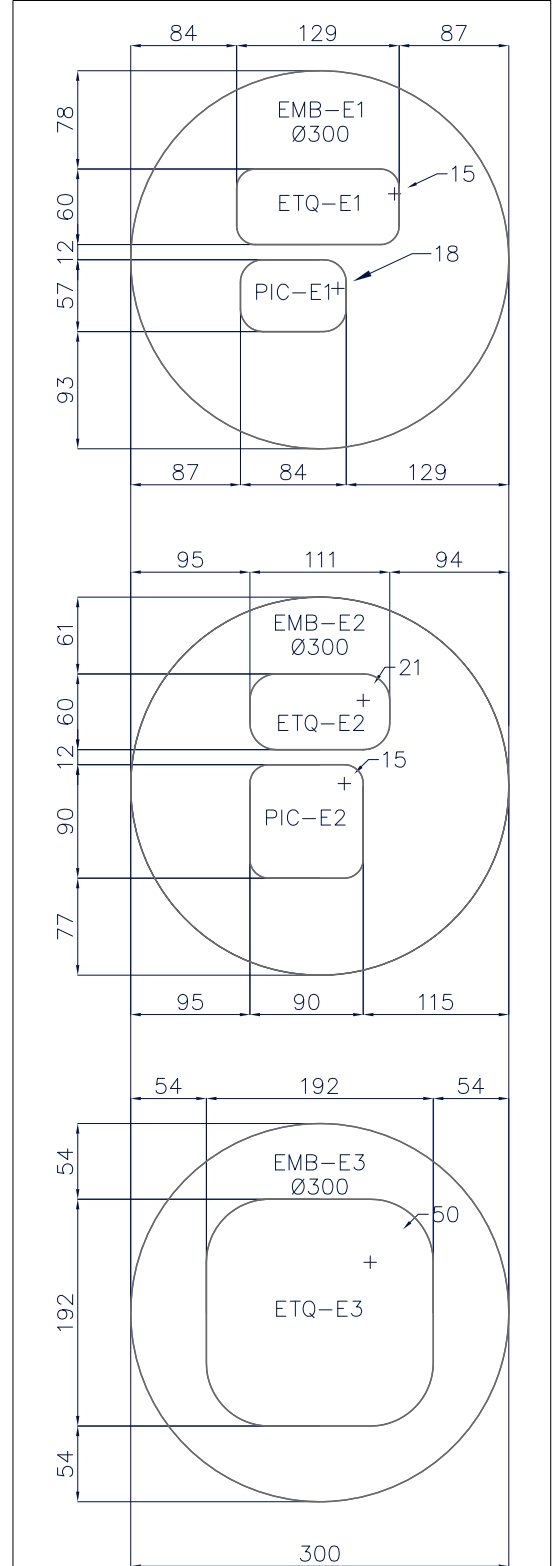

E 1/6

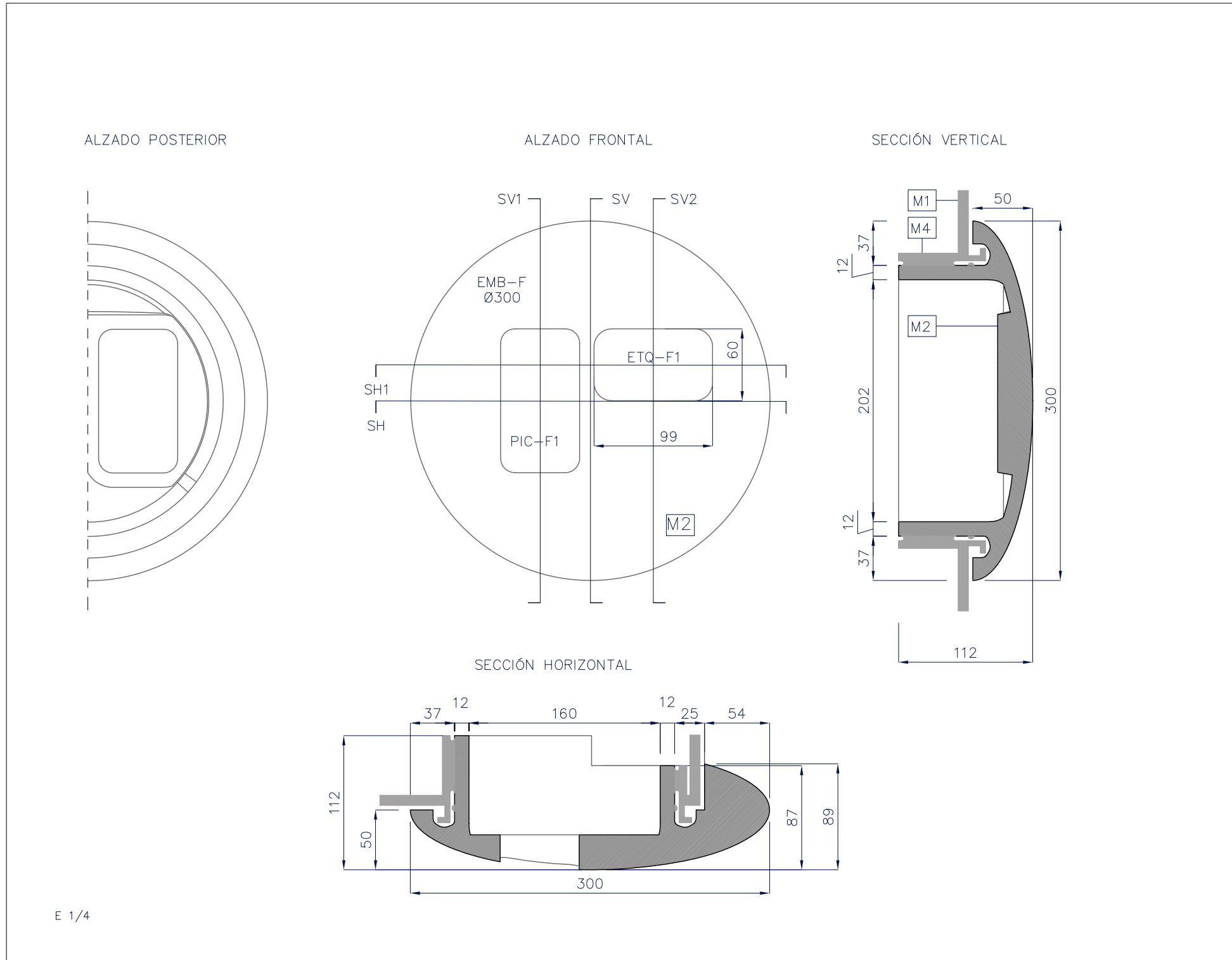

E 1/4

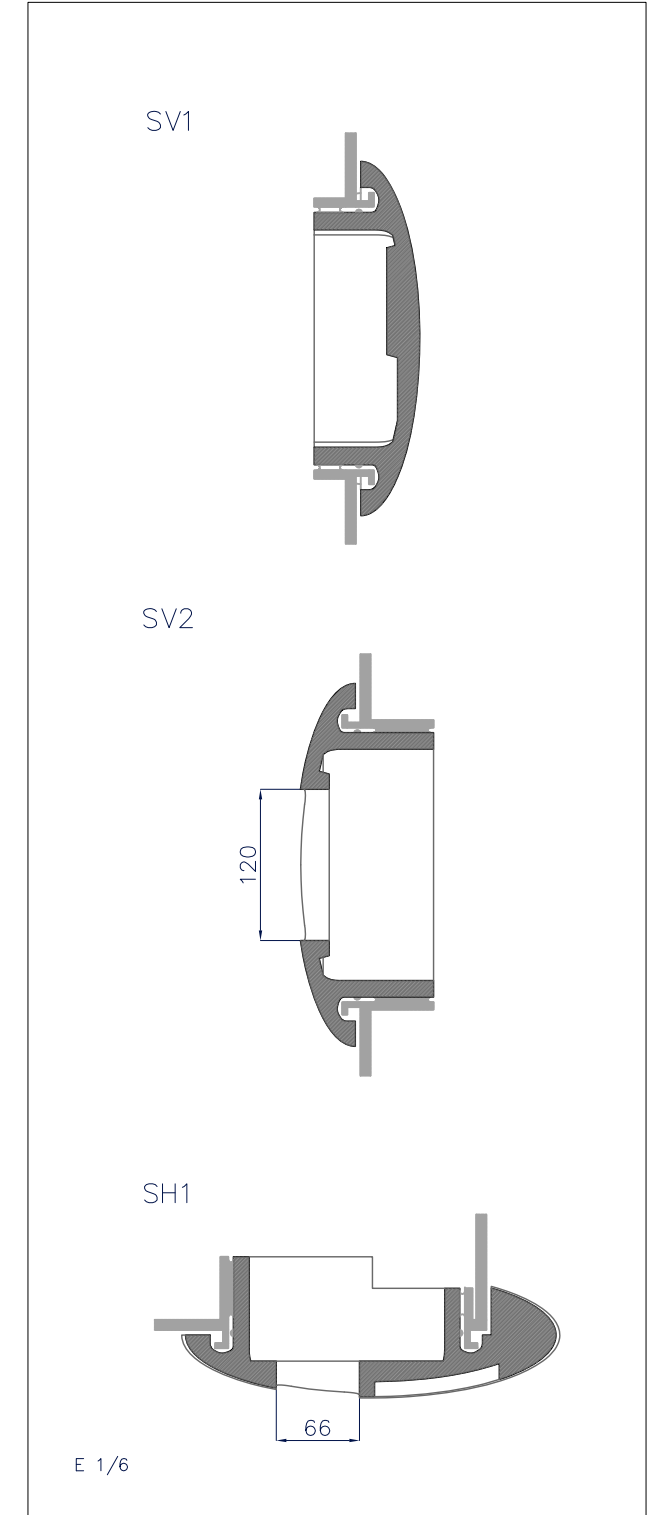

E 1/6

Materiales	
M1	Acero inoxidable S316L
M2	Fundición de aluminio anodizado color
M3	Fundición de aluminio anodizado natural
M4	Neopreno

ALZADO POSTERIOR

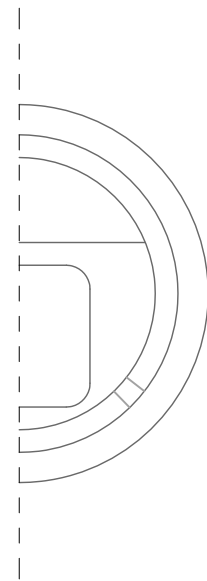

ALZADO FRONTAL

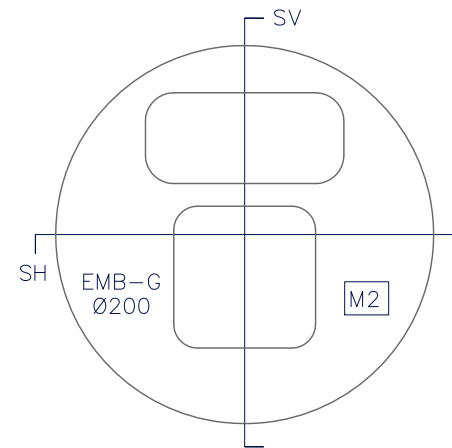

SECCIÓN VERTICAL

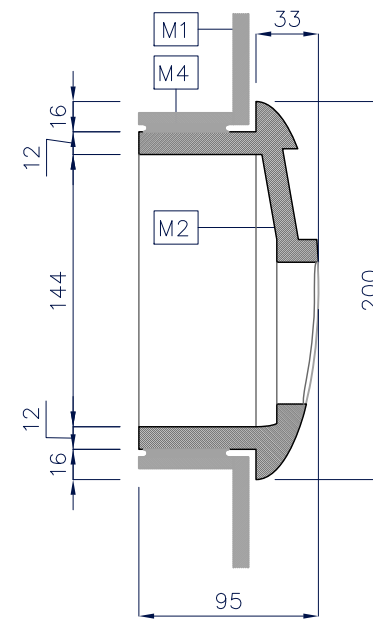

SECCIÓN HORIZONTAL

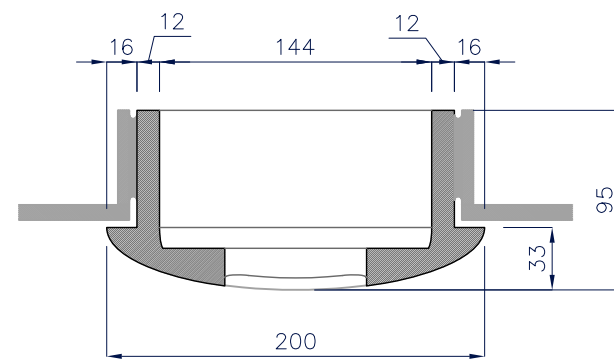

Materiales	
M1	Acero inoxidable S316L
M2	Fundición de aluminio anodizado color
M3	Fundición de aluminio anodizado natural
M4	Neopreno

E 1/4

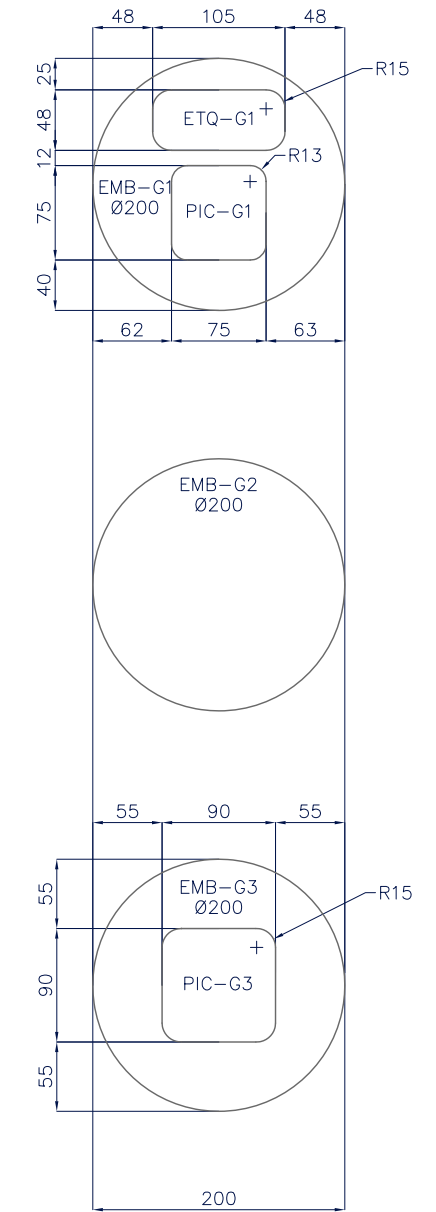

E 1/6



ALZADO POSTERIOR

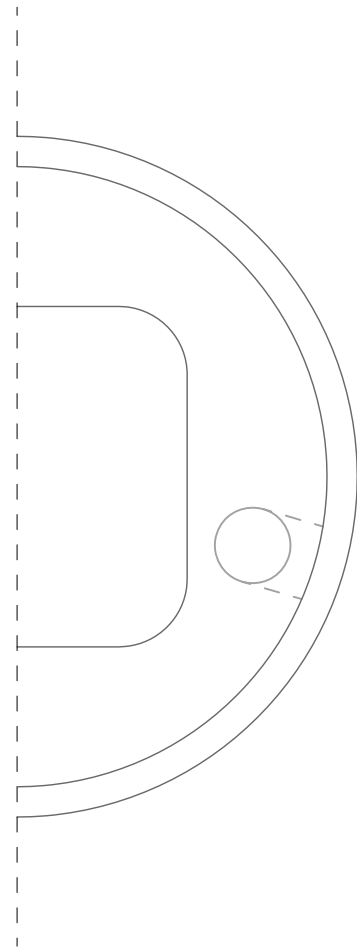

ALZADO FRONTAL

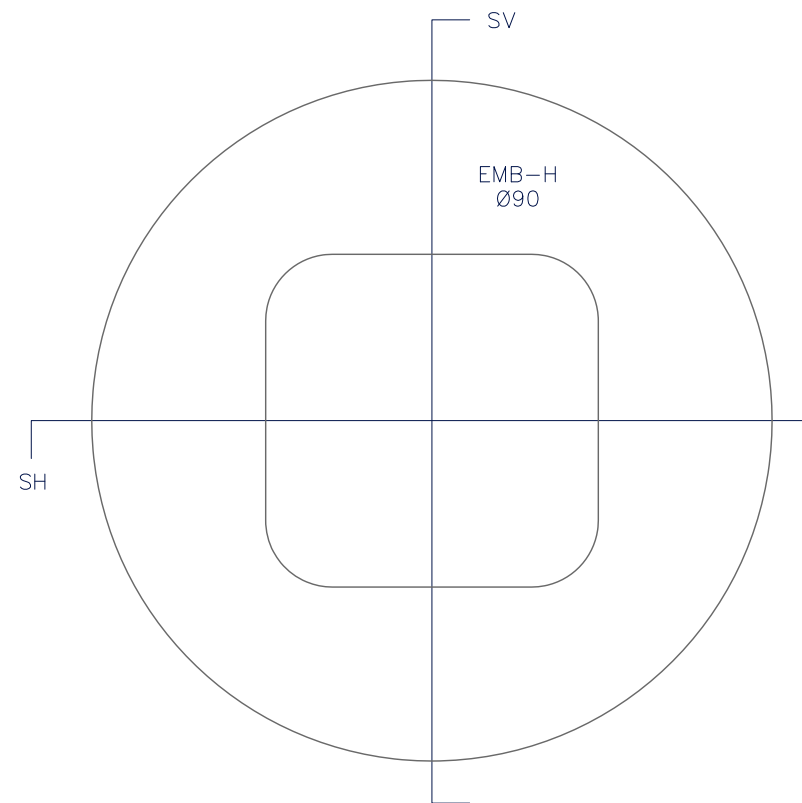

SECCIÓN VERTICAL

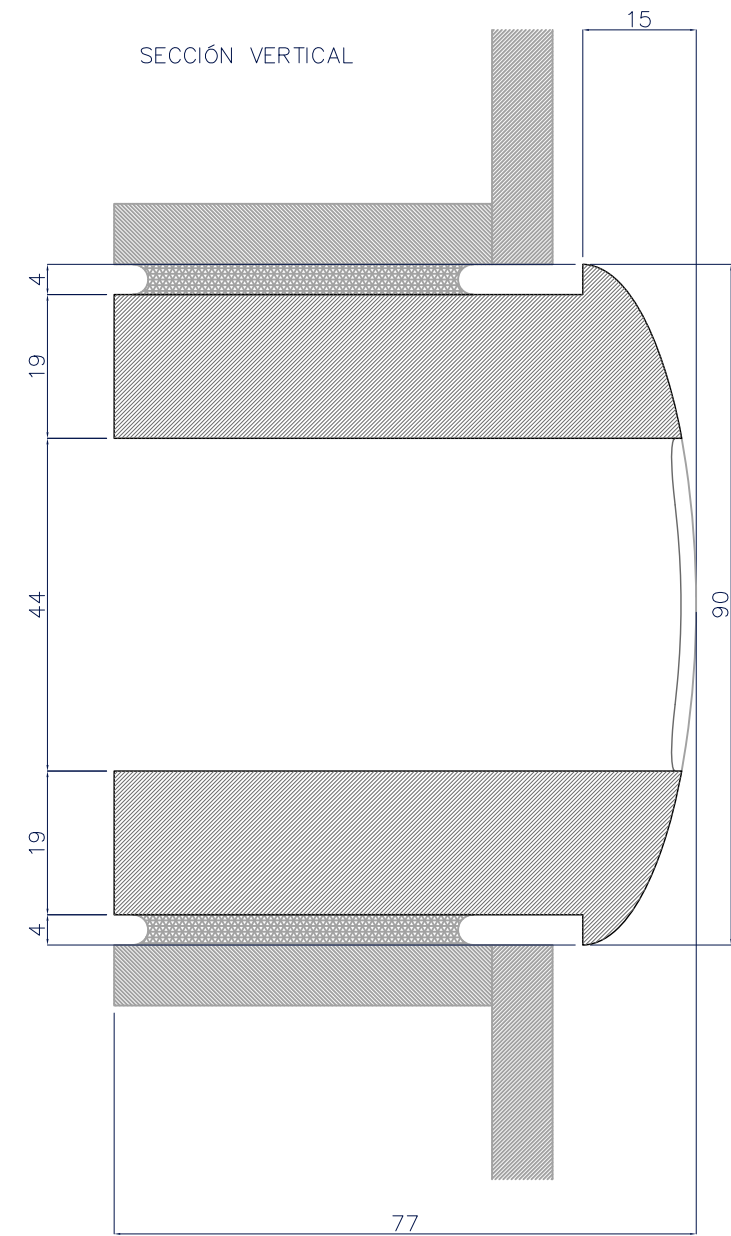

SECCIÓN HORIZONTAL

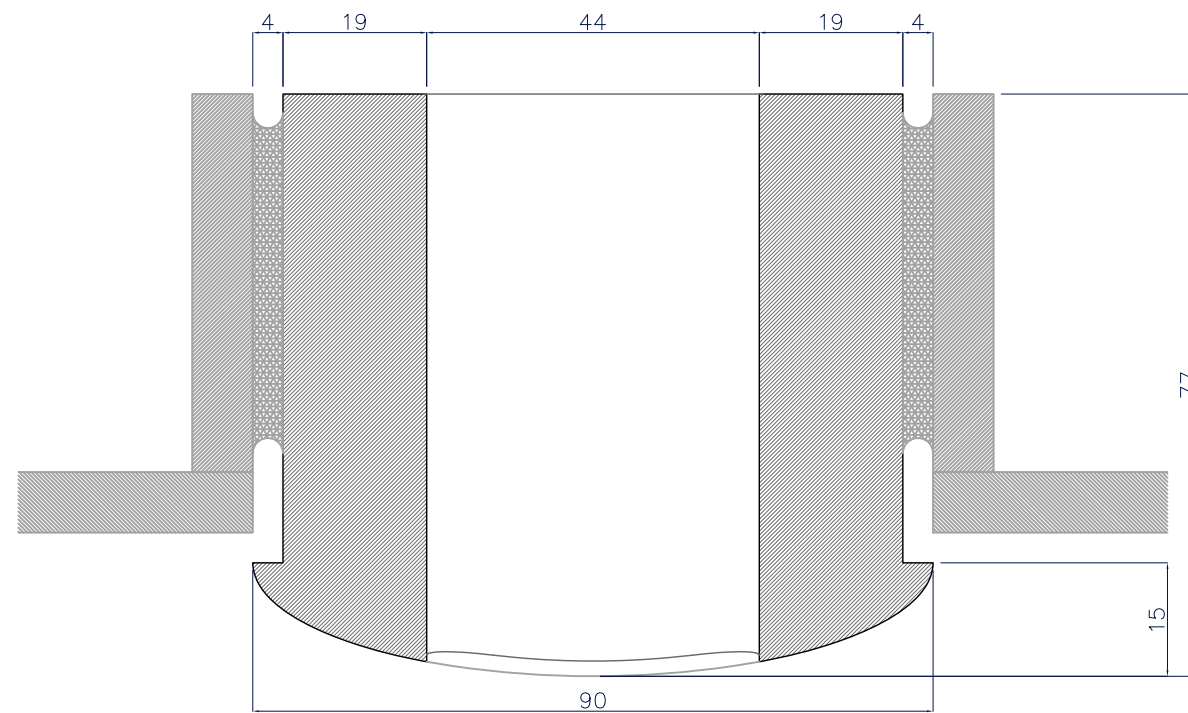

Materiales	
M1	Acero inoxidable S316L
M2	Fundición de aluminio anodizado color
M3	Fundición de aluminio anodizado natural
M4	Neopreno

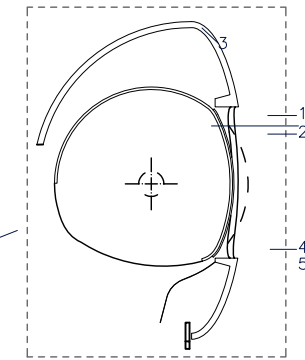
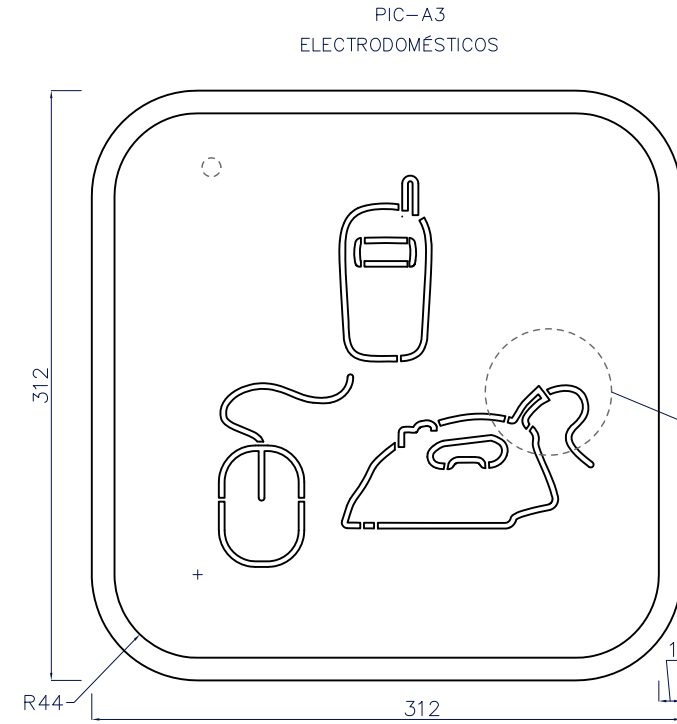
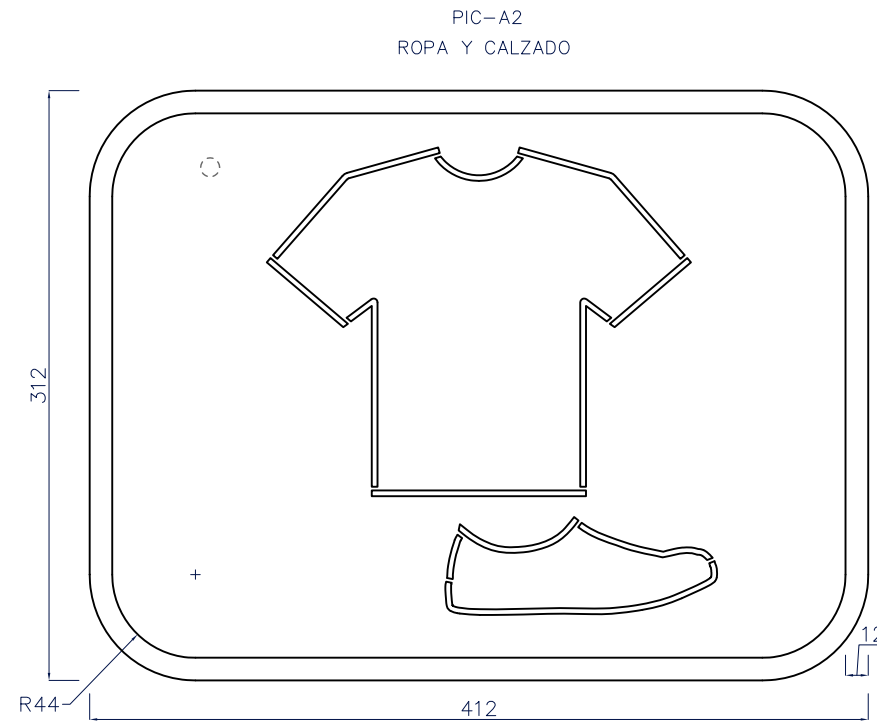
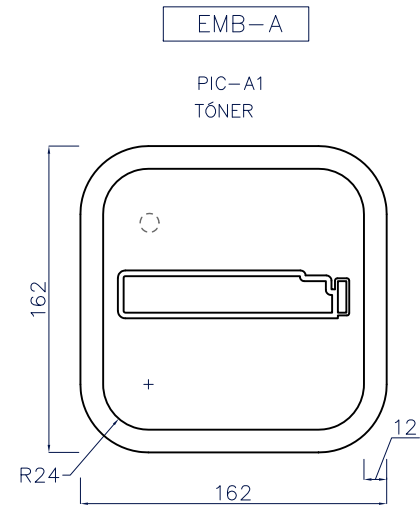

PIC-A2 Y PIC-A3 son las únicas chapas entre las puertas de embocadura que se curvan para formar el tambor del torno.

- 1 - Chapa pictograma
- 2 - Torno
- 3 - Eje torno
- 4 - Embocadura fundición
- 5 - Chapa encauzado

Todos los pictogramas irán provistos de pestañas que aseguran la continuidad de la pieza tras el corte.

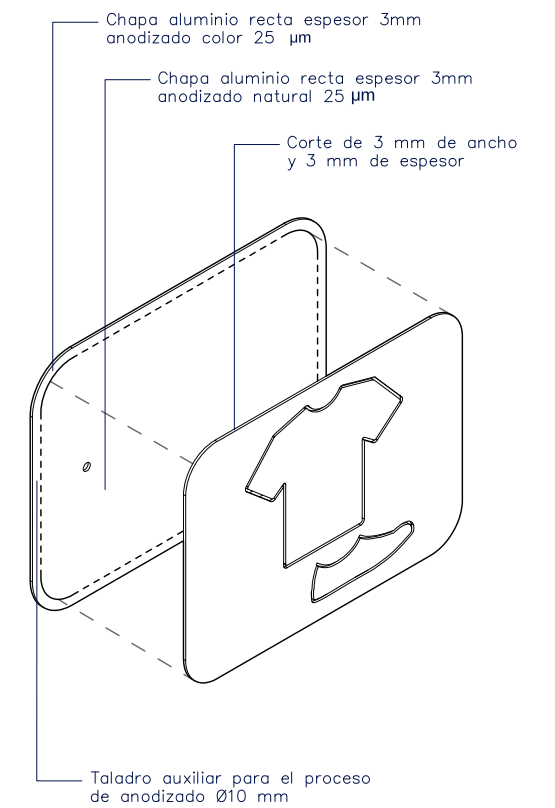
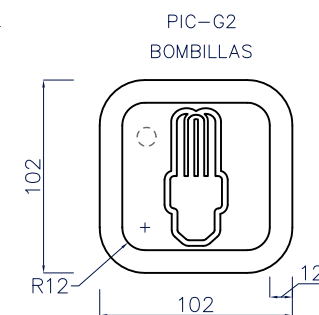
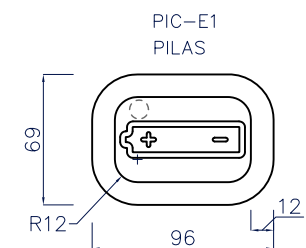
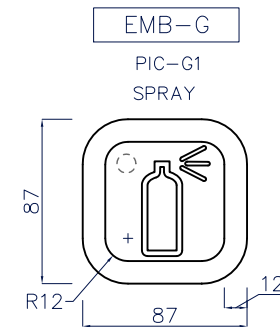
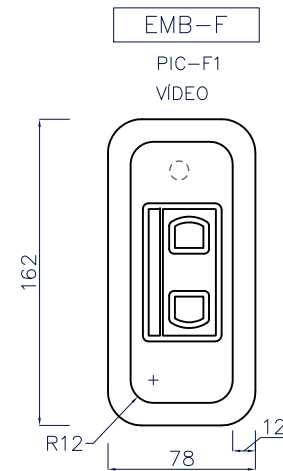
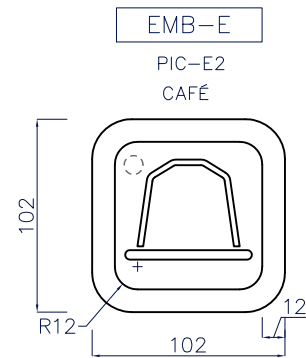
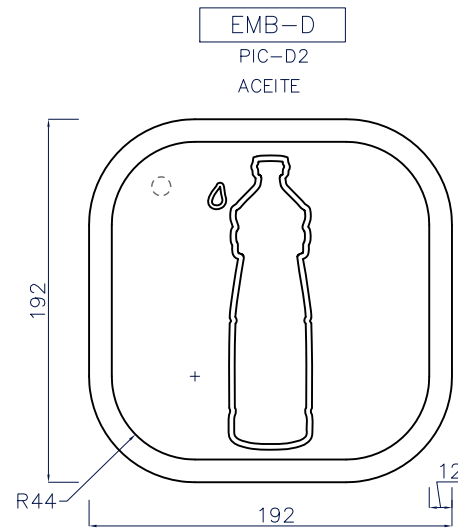
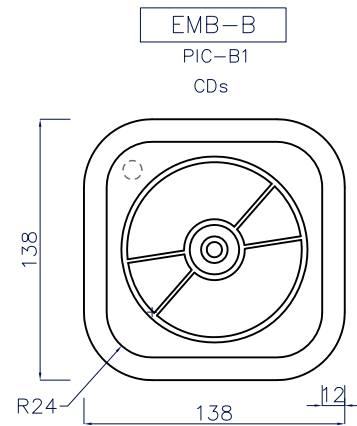

EMB-A

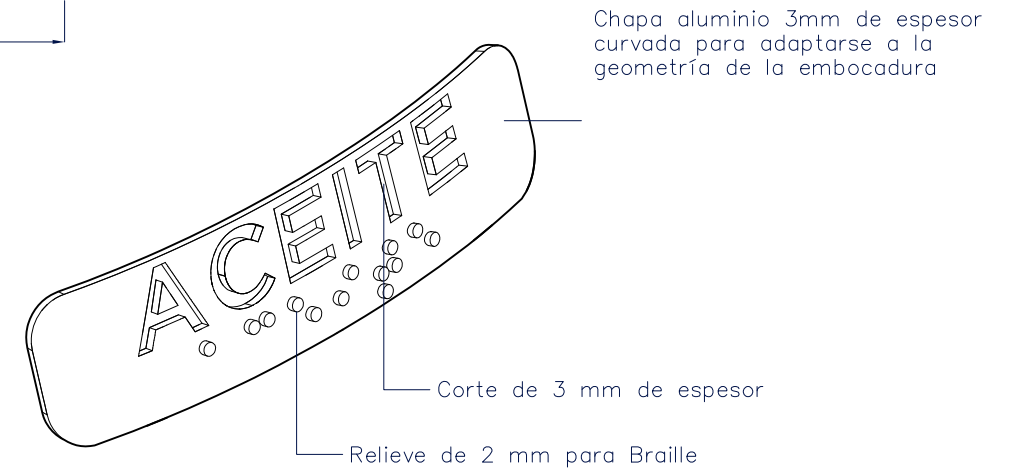
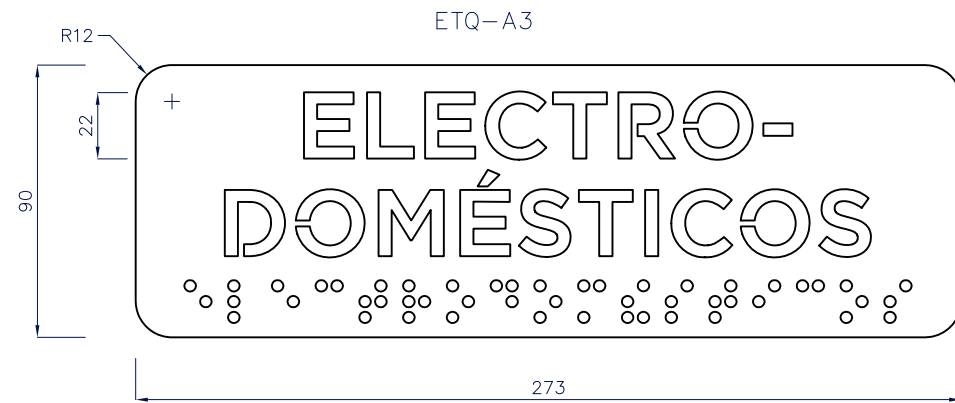
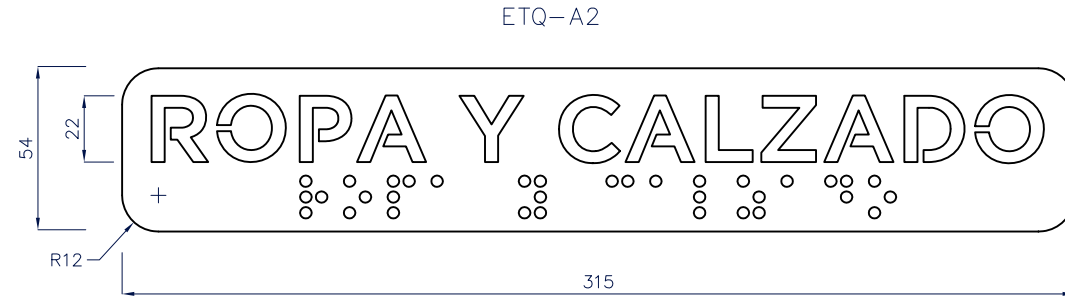
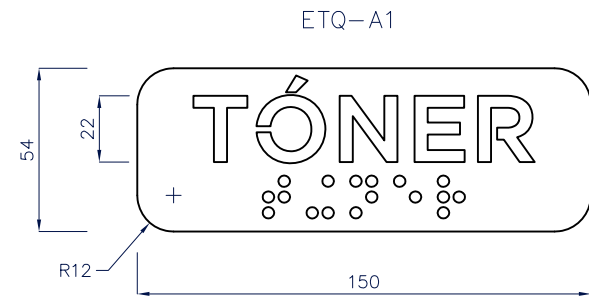

EMB-B

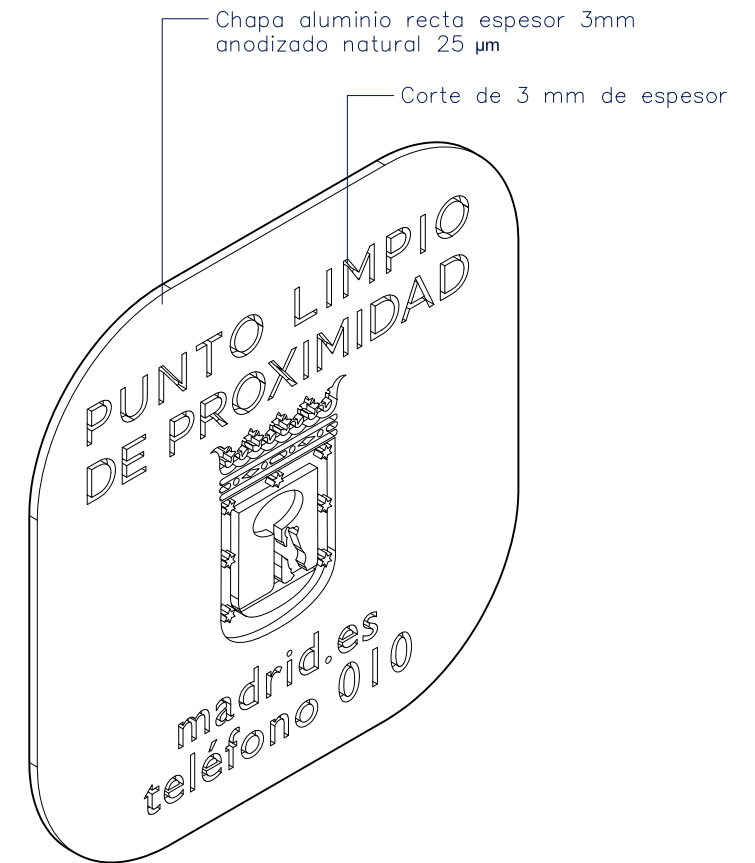
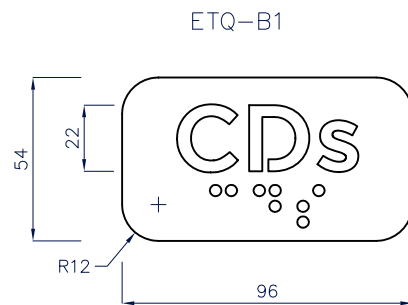
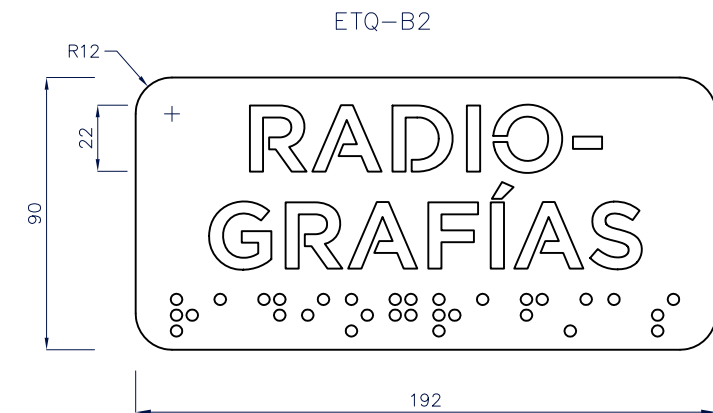

EMB-E

ETQ-E2

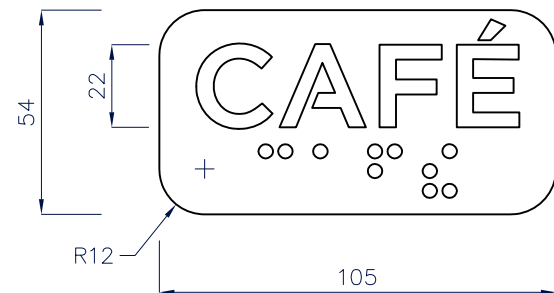

EMB-F

ETQ-F1

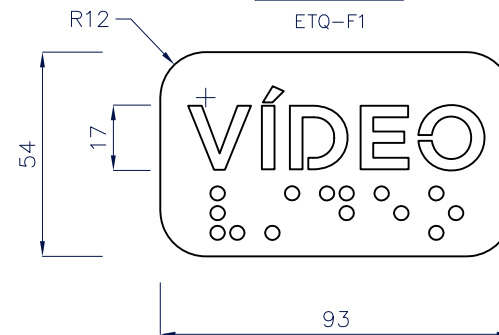

EMB-G

ETQ-G1

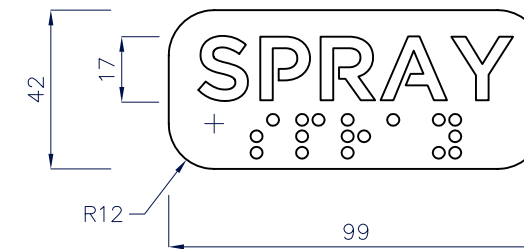

ETQ-E1

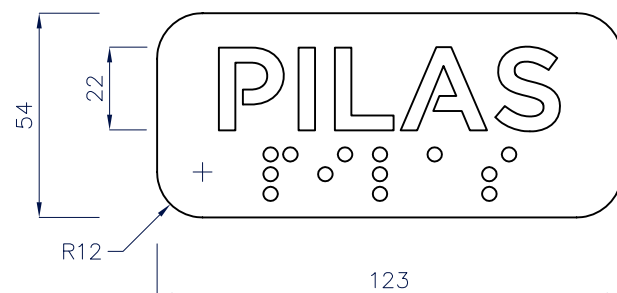

EMB-D

ETQ-D1

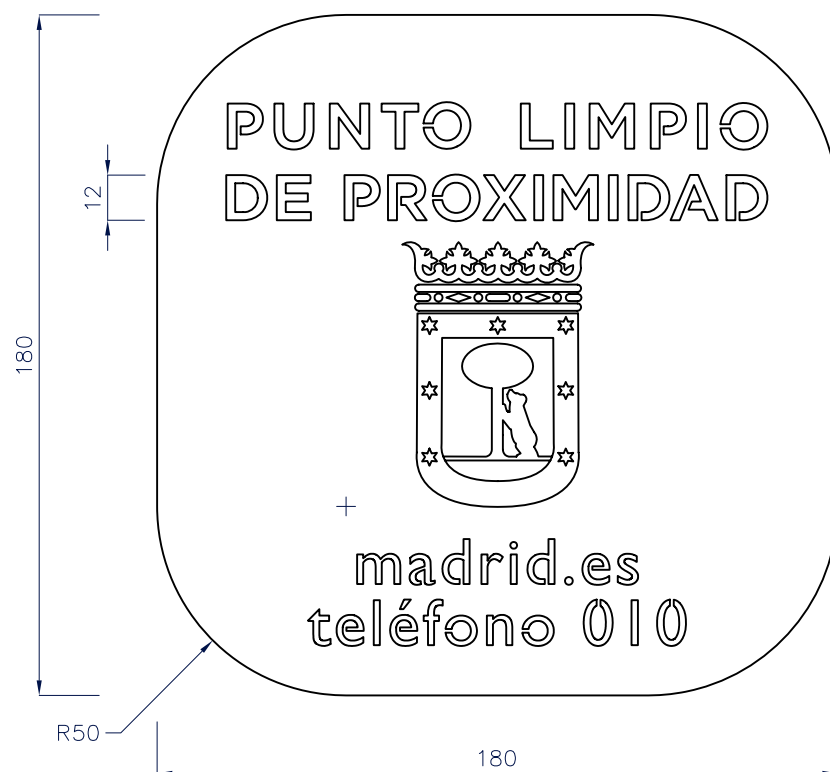

ETQ-D2

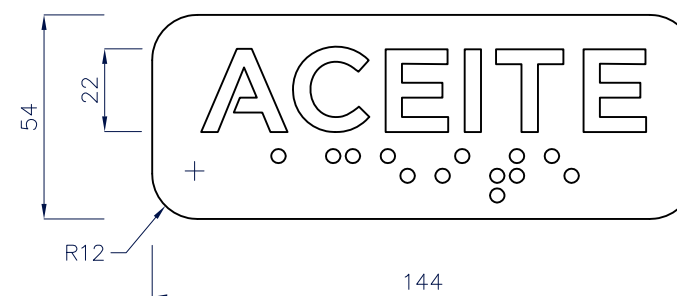

ETQ-E3

